

# CURRENT SENSOR

---

PRODUCT SERIES: STB-LA/S

PRODUCT PART NUMBER: STB-100LA/S

VERSION: Ver 2.2

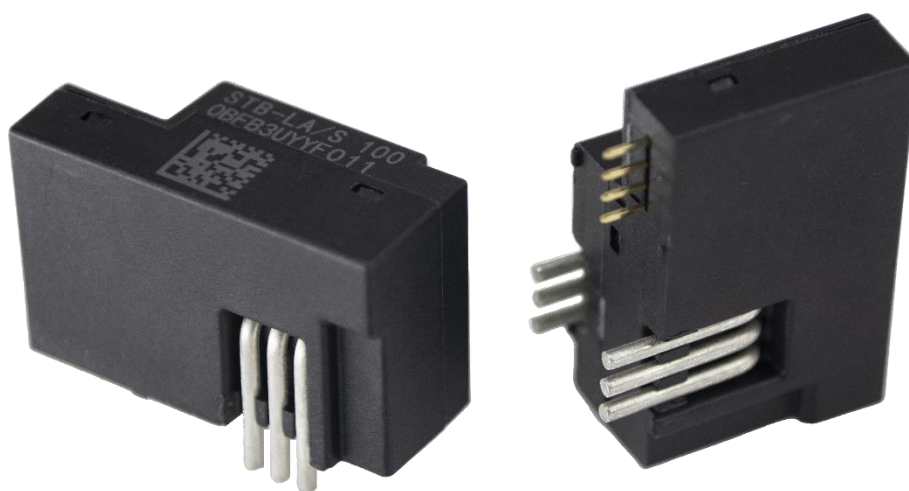

Sinomags Technology Co., Ltd.

Web site: [www.sinomags.com](http://www.sinomags.com)

## CONTENT

1.	Description .....	2
2.	Electrical parameters (STB-100LA/S).....	3
3.	Dimensions: STB-xxxLA/S .....	4
4.	PCB footprint (STB-xxxLA/S) .....	5
5.	Schematic diagram.....	6
6.	Delay times .....	6

## 1. Description

STB-LA/S series current sensors are based on close loop principle with TMR technology. The sensor can detect the current with DC, AC, pulse and irregular wave shape.

### Typical application

- Solar inverter
- Direct-current dynamo
- Uninterruptible Power Supplies (UPS)
- Switched model power supplies (SMPS)
- Variable frequency converter

### General parameters

Parameter	Symbol	Unit	Value	Remark
Working environment temperature	$T_A$	°C	-40 ~ 85	
Sensor operating limit temperature	$T_{SL}$	°C	-40 ~ 105	
Storage temperature	$T_S$	°C	-40 ~ 85	
Limit temperature of primary conductor	$T_{LP}$	°C	105	STB-xxxLA/S
Mass	m	g	15.3	STB-xxxLA/S

### Absolute parameters

Parameters	Symbol	Unit	Value
Supply voltage	$V_{CC_{max}}$	V	6
Maximum primary current	$I_{PN_{max}}$	A	10*I <sub>pn</sub>
ESD rating (HBM)	U_ESD_HBM	kV	4

Remark: the unrecoverable damage may occur when the product works on the conditions over the absolute maximum ratings. Long-time working on the absolute maximum ratings may cause the degradation on performance and reliability.

### Isolation parameters

Parameter	Symbol	Unit	Value	Remark
RMS voltage for AC test 50Hz/1 min	$U_d$	kV	4	
Impulse withstand voltage 1.2/50μs	$U_W$	kV	8	
Clearance distance (pri. -sec)	dCl	mm	10.2	Shortest distance through air
Creepage distance (pri. -sec)	dCp	mm	10.2	Shortest path along device body
Case material			V0	According to UL 94
Comparative tracking index	CTI	V	600	

## 2. Electrical parameters (STB-100LA/S)

Condition:  $V_{CC} = 5.0\text{ V}$ ,  $R_L = 10\text{ k}\Omega$ ,  $T_A = 25^\circ\text{C}$ , unless specified.

Parameters	Symbol	Unit	Min.	Typ.	Max.	Remark
Primary nominal rms current	$I_{PN}$	A		100		@-40°C~105°C $V_{CC} = 5\text{V}$
Primary current measuring range	$I_{PM}$	A	-220		220	@85°C $V_{CC} = 5\text{V}$ ,
Supply voltage	$V_{CC}$	V	4.75	5	5.25	
Consumption current	$I_{CC}$	mA	7	9+ $I_P/NS*10$ 00	350	NS = 1000
Reference voltage	$V_{ref}$	V	2.48	2.5	2.52	
Output voltage	$V_{out}$	V	2.475		2.525	$V_{out}@ 0\text{ A}$
Electrical offset voltage	$V_{oe}$	mV	-5		5	100 % tested ( $V_{out} - V_{ref}$ )@ 0 A
Full-scale voltage	$V_{FS}$	V		$\pm 0.625$		( $V_{out} - V_{ref}$ )@ $I_{PN}$
Theoretical sensitivity	$G_{tk}$	mV/A		6.25		0.625 V @ $I_{PN}$
Internal resistance of Reference input	ohm	$R_i, R_{ef}$		670		
Output resistance of $V_{out}$	ohm	$R_L$		1		
Sensitivity error	$G_{ree}$	% of $I_{PN}$	-0.7		0.7	
Linearity error within $I_{PN}$	$\varepsilon_L$	% of $I_{PN}$	-0.1		0.1	@25°C
Reaction time @ 10 % of $I_P$	$t_{d10}$	$\mu\text{s}$		0.5		
Step response time @ 90 % of $I_P$	$t_{d90}$	$\mu\text{s}$		0.5		
-3 dB band width	BW	kHz		300		
Noise DC ~ 10 kHz DC ~ 100 kHz	$V_{noise}$	mVpp		5 6		
Accuracy @ 25°C	X	% of $I_{PN}$	-0.8		0.8	
Accuracy @ 85 °C	$X_T$	% of $I_{PN}$	-1.1		1.1	
Capacitive Load	CL	pF			100	

### 3. Dimensions: STB-xxxLA/S

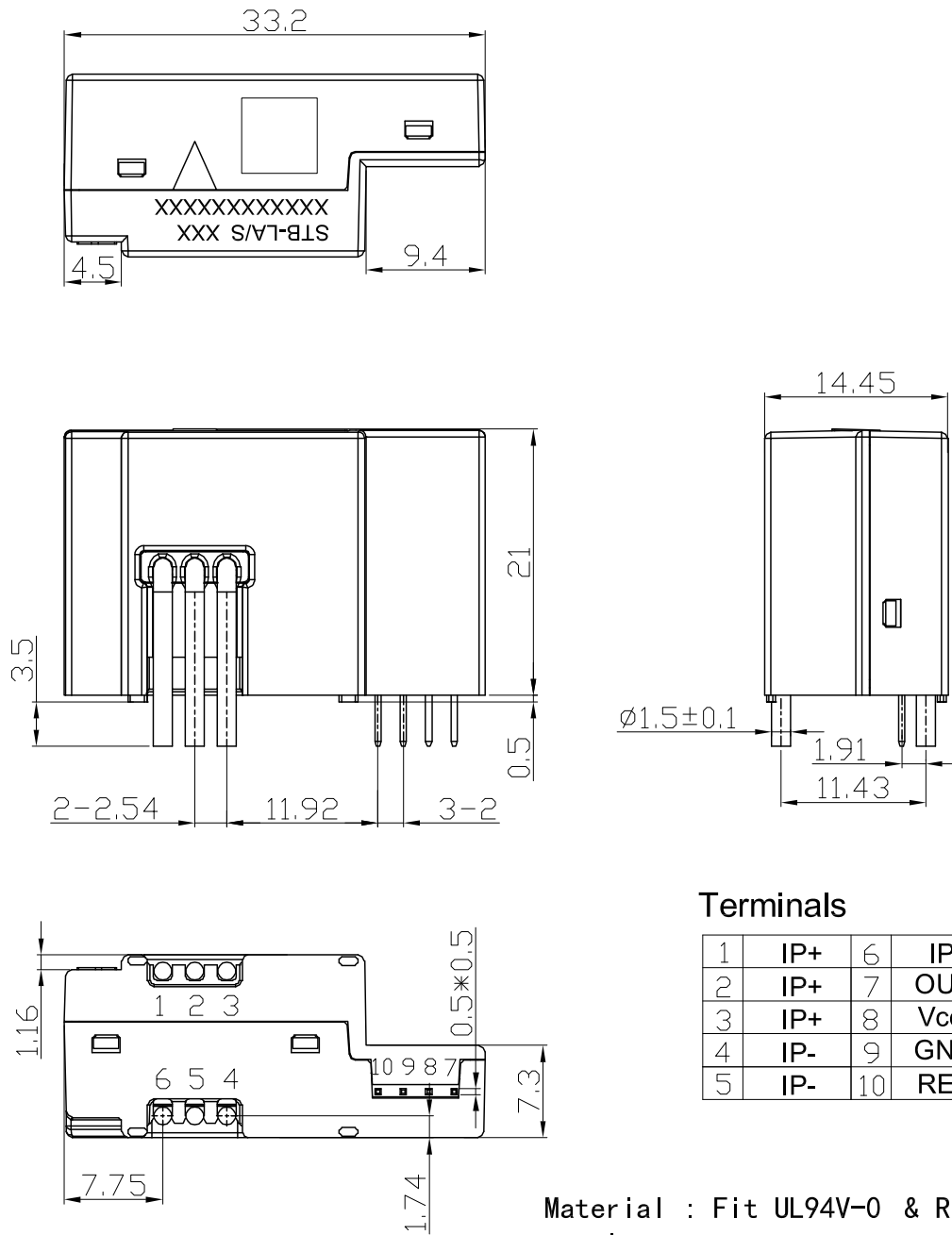

#### Terminals

1	IP+	6	IP-
2	IP+	7	OUT
3	IP+	8	Vcc
4	IP-	9	GND
5	IP-	10	REF

Material : Fit UL94V-0 & RoHS requirements ;

General tolerance :  $\pm 0.5$

Unit :mm

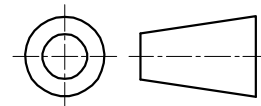

#### 4. PCB footprint (STB-xxxLA/S)

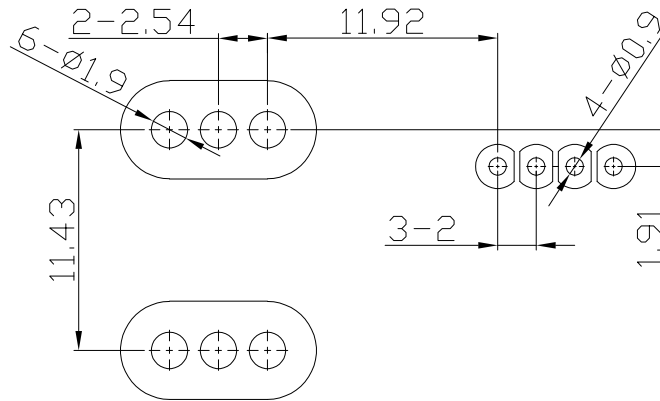

TOP side view

##### Assembly on PCB

- Recommended PCB hole diameter: 1.1mm for secondary pins,
- Maximum PCB thickness: 2.4 mm (can be customized per request).
- Wave soldering profile: maximum 260°C for 10 seconds.

## 5. Schematic diagram

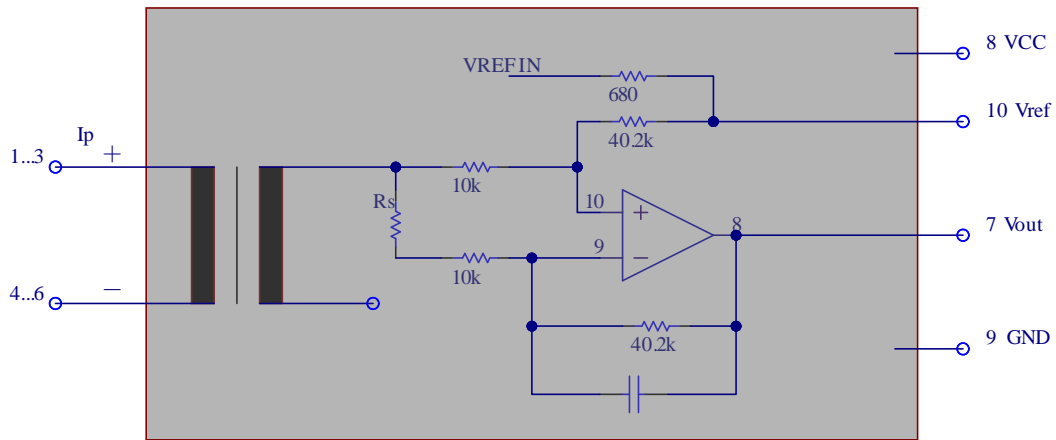

## 6. Delay times

The delay time  $t_{D10}$  @ 10% and the delay time  $t_{D90}$  @ 90% with respect to the primary are shown in the next figure. Both slightly depend on the primary current  $di/dt$ . They are measured at nominal current.

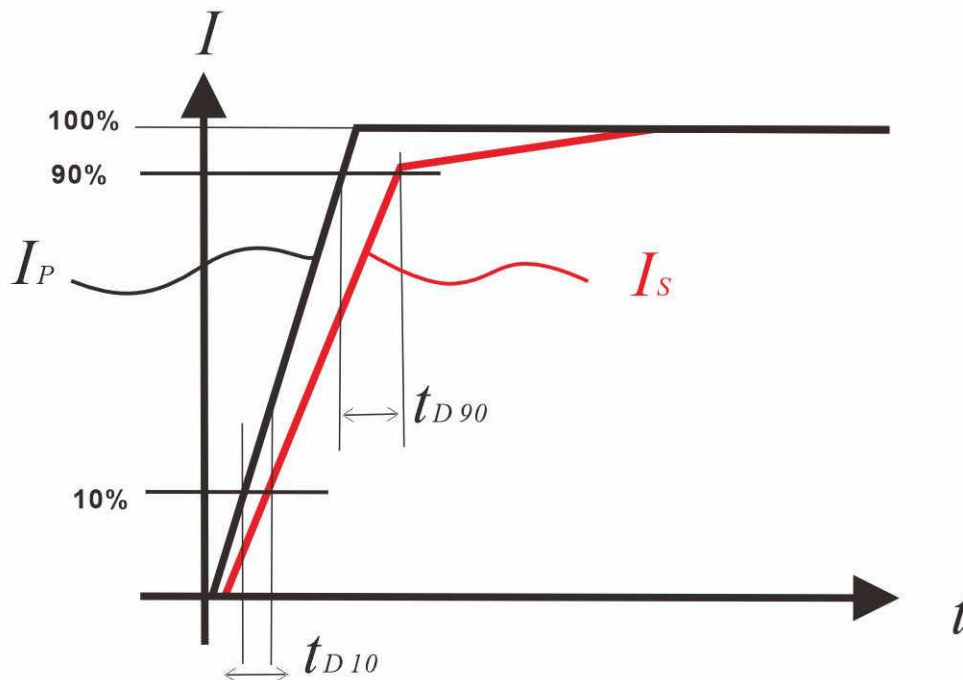

## 7. High temperature derating curve

When the test condition is  $V_{CC}=5V$ ,  $T_A=25^{\circ}C$ , the maximum current of the primary side can be accepted as 220A DCI.

When the test condition is  $V_{CC}=5V$ ,  $T_A=85^{\circ}C$ , the maximum current of the primary side can be accepted as 220A DCI.

