

# CURRENT SENSOR

PRODUCT SERIES: STK-HO/2

STK-60HO/2, STK-100HO/2

STK-120HO/2, STK-150HO/2

PRODUCT PARNUMBER:

STK-180HO/2, STK-240HO/2

STK-250HO/2

REVISION: Ver 1.1



Sinomags Technology Co., Ltd.

Web site: [www.sinomags.com](http://www.sinomags.com)

## CONTENT

1.	Description.....	2
2.	Electrical performance of STK-60HO/2.....	3
3.	Electrical performance of STK-100HO/2.....	5
4.	Electrical performance of STK-120HO/2.....	7
5.	Electrical performance of STK-150HO/2.....	9
6.	Electrical performance of STK-180HO/2.....	11
7.	Electrical performance of STK-240HO/2.....	13
8.	Electrical performance of STK-250HO/2.....	15
9.	Output voltage VS primary current of STK-HO/2.....	16
10.	Frequency bandwidth .....	20
11.	Step response time .....	20
12.	PCB Footprint in mm .....	21
13.	Dimensions & Pins & Footprint .....	22
14.	General information on OCD .....	23

## 1. Description

STK-HO/2 current sensor is based on the open loop principle. DC, AC, pulses and any kind of irregular wave can be measured by the current sensor under the isolated conditions.

### Typical application

- AC Variable speed drives
- UPS
- Power supplies for welding applications
- MPPT
- Switched model power supplies (SMPS)
- Static converters for DC motor drives
- Battery supplied applications
- Combiner box

### General parameters

Parameter	Symbol	Unit	Value
Working temperature	T <sub>a</sub>	°C	-40 ~ 105
Storage temperature	T <sub>stg</sub>	°C	-40 ~ 105
Mass	m	g	33.7

### Absolute parameters

Parameters	Symbol	Unit	Value
Supply voltage (not-destructive)	V <sub>c</sub>	V	6
ESD rating (HBM)	U <sub>esd</sub>	kV	4

Remark: the unrecoverable damage may occur when the product works on the conditions over the absolute maximum ratings. Long-time working on the absolute maximum ratings may cause the degradation on performance and reliability.

### Isolation parameters

Parameter	Symbol	Unit	Value	Remark
RMS voltage for AC test	U <sub>d</sub>	kV	4.3	@ 50Hz/1 min
Impulse withstand voltage	Ū <sub>w</sub>	kV	8	1.2/50μs
Case material	-	-	V0	According to UL 94
Comparative tracking index	CTI	-	600	
Clearance (pri. - sec.)	D <sub>ci</sub>	mm	>8	Shortest distance through air
Creepage distance (pri. - sec.)	D <sub>cp</sub>	mm	>8	When mounted on PCB with recommended layout

## 2. Electrical performance of STK-60HO/2

$V_{cc} = 5\text{ V}$ ,  $T_A = 25^\circ\text{C}$

Parameter	Symbol	Unit	Min	Typ	Max	Comment
Primary nominal current rms	$I_{pn}$	A		60		
Primary current measuring range	$I_{pm}$	A	-150		150	
Supply voltage	$V_{cc}$	V	4.75	5	5.25	
Current consumption	$I_{cc}$	mA		6	10	
Reference voltage	$V_{ref}$	V	2.48	2.5	2.52	Output function
Electrical offset voltage @ $I_P = 0\text{ A}$	$V_{oe}$	mV	-8		8	$V_{out} - V_{ref} @ V_{ref} = 2.5\text{ V}$
Electrical offset current referred to primary	$I_{oe}$	A	-0.6		0.6	
Output voltage range @ $I_P M$	$V_{FS}$	V	-2		2	$(V_{out} - V_{ref}) @ I_{pm} - V_{oe}$
Internal $V_{ref}$ resistance	$R_{ref}$	$\Omega$	4.5	12	19.5	Series
Internal output resistance	$R_{out}$	$\Omega$	4.5	12	19.5	Series
Difference of output resistance ( $R_{ref} - R_{out}$ )	$R_{oe}$	$\Omega$	-5		5	Series
OCD output mask time ①	$T_{mask}$	$\mu\text{s}$		2		
OCD output hold time ②	$T_{hold}$	ms		1.5		
Theoretical gain	$G$	mV/A		13.333		800 mV @ $I_P N$
Temperature drift of $V_{oe}$	$V_{oe\_TR\text{ange}}$	mV	-10		10	$-40^\circ\text{C} \sim 105^\circ\text{C}$
Error of gain	$Err\_G$	% $G_{th}$	-0.5		0.5	Trimmed in the factory @ $25^\circ\text{C}$
Temperature drift of gain	$G\_TR$	% $G_{th}$	-1		1	@ $-40^\circ\text{C} \sim 105^\circ\text{C}$
Rated linearity error	Non- $L_{pn}$	% $I_{pn}$	-0.5		0.5	$\pm I_{pn}$
Linearity error @ $I_{pm}$	Non- $L_{pm}$	% $I_{pm}$	-1		1	$\pm I_{pm}$
Step response time	$t_{res}$	$\mu\text{s}$		1.5	2	@ 90% of $I_{pn}$
Frequency bandwidth (-3dB)	BW	kHz		200		No RC circuit
Output voltage noise	$V_{noise}$	mVpp		4.4		@140kHz Sampling Rate
Primary current, detection threshold ③	$I_{pth}$	A	$2.64 * I_{pn}$	$2.93 * I_{pn}$	$3.22 * I_{pn}$	Peak value $\pm 10\%$ overcurrent detection OCD
Accuracy @ $25^\circ\text{C}$	X	% of $I_{pn}$	-1		1	@ $25^\circ\text{C}$
Accuracy @ $-40^\circ\text{C} \sim 105^\circ\text{C}$ ④	$X_{TR\text{ange}}$	% of $I_{pn}$	-3		3	$-40^\circ\text{C} \sim 105^\circ\text{C}$

## Remarks:

① ②. To prevent nuisance tripping, a tmask time is used. If an over current occurs, but does not persist for the duration of tmask, it does not trigger the fault pin. This prevents short transient spikes from causing erroneous fault detections. In the event where transient error reporting is desired, the tmask can be disabled. If the fault is triggered, it will remain active for a minimum time of thold and up to the end of the fault condition, whichever is greater.

③. STK-HO/2 products may be ordered on request with a dedicated setting of the Trigger current . The product has a built-in overcurrent detection function, When the output voltage detected by the product exceeds the threshold, it is judged to be overcurrent and the output of fault pin changes to low level .

④. the accuracy @ -40°C~105°C,  $X\_TRange = ((V_{out} - V_{ref})@ In @ T_x) - V_{oe@ 25^\circ C} - G_{th} * In) / V_{FS}$ , where  $T_x$  represents present temperature,  $G_{th}$  is fitted gain at room temperature .

### 3. Electrical performance of STK-100HO/2

$V_{cc} = 5\text{ V}$ ,  $T_A = 25^\circ\text{C}$

Parameter	Symbol	Unit	Min	Typ	Max	Comment
Primary nominal current rms	$I_{pn}$	A		100		
Primary current measuring range	$I_{pm}$	A	-250		250	
Supply voltage	$V_{cc}$	V	4.75	5	5.25	
Current consumption	$I_{cc}$	mA		6	10	
Reference voltage	$V_{ref}$	V	2.48	2.5	2.52	Output function
Electrical offset voltage @ $I_P = 0\text{ A}$	$V_{oe}$	mV	-8		8	$V_{out} - V_{ref} @ V_{ref} = 2.5\text{ V}$
Electrical offset current referred to primary	$I_{oe}$	A	-1		1	
Output voltage range @ $I_P M$	$V_{FS}$	V	-2		2	$((V_{out} - V_{ref}) @ I_{pm}) - V_{oe}$
Internal $V_{ref}$ resistance	$R_{ref}$	$\Omega$	4.5	12	19.5	Series
Internal output resistance	$R_{out}$	$\Omega$	4.5	12	19.5	Series
Difference of output resistance ( $R_{ref} - R_{out}$ )	$R_{oe}$	$\Omega$	-5		5	Series
OCD output mask time ①	$T_{mask}$	$\mu\text{s}$		2		
OCD output hold time ②	$T_{hold}$	ms		1.5		
Theoretical gain	$G$	mV/A		8		800 mV @ $I_P N$
Temperature drift of $V_{oe}$	$V_{oe\_TR\text{ange}}$	mV	-10		10	$-40^\circ\text{C} \sim 105^\circ\text{C}$
Error of gain	$Err\_G$	% $G_{th}$	-0.5		0.5	Trimmed in the factory @ $25^\circ\text{C}$
Temperature drift of gain	$G\_TR$	% $G_{th}$	-1		1	@ $-40^\circ\text{C} \sim 105^\circ\text{C}$
Rated linearity error	Non- $L_{pn}$	% $I_{pn}$	-0.5		0.5	$\pm I_{pn}$
Linearity error @ $I_{pm}$	Non- $L_{pm}$	% $I_{pm}$	-1		1	$\pm I_{pm}$
Step response time	$t_{res}$	$\mu\text{s}$		1.5	2	@ 90% of $I_{pn}$
Frequency bandwidth (-3dB)	BW	kHz		200		No RC circuit
Output voltage noise	$V_{noise}$	mVpp		4.4		@140kHz Sampling Rate
Primary current, detection threshold ③	$I_{pth}$	A	$2.64 * I_{pn}$	$2.93 * I_{pn}$	$3.22 * I_{pn}$	Peak value $\pm 10\%$ overcurrent detection OCD
Accuracy @ $25^\circ\text{C}$	X	% of $I_{pn}$	-1		1	@ $25^\circ\text{C}$
Accuracy @ $-40^\circ\text{C} \sim 105^\circ\text{C}$ ④	$X_{TR\text{ange}}$	% of $I_{pn}$	-3		3	$-40^\circ\text{C} \sim 105^\circ\text{C}$

---

**Remarks:**

① ②. To prevent nuisance tripping, a tmask time is used. If an over current occurs, but does not persist for the duration of tmask, it does not trigger the fault pin. This prevents short transient spikes from causing erroneous fault detections. In the event where transient error reporting is desired, the tmask can be disabled. If the fault is triggered, it will remain active for a minimum time of thold and up to the end of the fault condition, whichever is greater.

③. STK-HO/2 products may be ordered on request with a dedicated setting of the Trigger current . The product has a built-in overcurrent detection function, When the output voltage detected by the product exceeds the threshold, it is judged to be overcurrent and the output of fault pin changes to low level .

④. the accuracy @ -40°C~105°C,  $X\_TRange = ((V_{out} - V_{ref})@ In @ T_x) - V_{oe@ 25^\circ C} - G_{th} * In) / V_{FS}$ , where  $T_x$  represents present temperature,  $G_{th}$  is fitted gain at room temperature .

#### 4. Electrical performance of STK-120HO/2

$V_{cc} = 5\text{ V}$ ,  $T_A = 25^\circ\text{C}$

Parameter	Symbol	Unit	Min	Typ	Max	Comment
Primary nominal current rms	$I_{pn}$	A		120		
Primary current measuring range	$I_{pm}$	A	-300		300	
Supply voltage	$V_{cc}$	V	4.75	5	5.25	
Current consumption	$I_{cc}$	mA		6	10	
Reference voltage	$V_{ref}$	V	2.48	2.5	2.52	Output function
Electrical offset voltage @ $I_P = 0\text{ A}$	$V_{oe}$	mV	-8		8	$V_{out} - V_{ref} @ V_{ref} = 2.5\text{ V}$
Electrical offset current referred to primary	$I_{oe}$	A	-1.2		1.2	
Output voltage range @ $I_P M$	$V_{FS}$	V	-2		2	$(V_{out} - V_{ref}) @ I_{pm} - V_{oe}$
Internal $V_{ref}$ resistance	$R_{ref}$	$\Omega$	4.5	12	19.5	Series
Internal output resistance	$R_{out}$	$\Omega$	4.5	12	19.5	Series
Difference of output resistance ( $R_{ref} - R_{out}$ )	$R_{oe}$	$\Omega$	-5		5	Series
OCD output mask time ①	$T_{mask}$	$\mu\text{s}$		2		
OCD output hold time ②	$T_{hold}$	ms		1.5		
Theoretical gain	$G$	mV/A		6.667		800 mV @ $I_P N$
Temperature drift of $V_{oe}$	$V_{oe\_TR\ range}$	mV	-10		10	$-40^\circ\text{C} \sim 105^\circ\text{C}$
Error of gain	$Err\_G$	% $G_{th}$	-0.5		0.5	Trimmed in the factory @ $25^\circ\text{C}$
Temperature drift of gain	$G\_TR$	% $G_{th}$	-1		1	@ $-40^\circ\text{C} \sim 105^\circ\text{C}$
Rated linearity error	Non- $L_{pn}$	% $I_{pn}$	-0.5		0.5	$\pm I_{pn}$
Linearity error @ $I_{pm}$	Non- $L_{pm}$	% $I_{pm}$	-1		1	$\pm I_{pm}$
Step response time	$t_{res}$	$\mu\text{s}$		1.5	2	@ 90% of $I_{pn}$
Frequency bandwidth (-3dB)	BW	kHz		200		No RC circuit
Output voltage noise	$V_{noise}$	mVpp		4.4		@140kHz Sampling Rate
Primary current, detection threshold ③	$I_{pth}$	A	$2.64 * I_{pn}$	$2.93 * I_{pn}$	$3.22 * I_{pn}$	Peak value $\pm 10\%$ overcurrent detection OCD
Accuracy @ $25^\circ\text{C}$	X	% of $I_{pn}$	-1		1	@ $25^\circ\text{C}$
Accuracy @ $-40^\circ\text{C} \sim 105^\circ\text{C}$ ④	$X_{TR\ range}$	% of $I_{pn}$	-3		3	$-40^\circ\text{C} \sim 105^\circ\text{C}$

## Remarks:

① ②. To prevent nuisance tripping, a tmask time is used. If an over current occurs, but does not persist for the duration of tmask, it does not trigger the fault pin. This prevents short transient spikes from causing erroneous fault detections. In the event where transient error reporting is desired, the tmask can be disabled. If the fault is triggered, it will remain active for a minimum time of thold and up to the end of the fault condition, whichever is greater.

③. STK-HO/2 products may be ordered on request with a dedicated setting of the Trigger current . The product has a built-in overcurrent detection function, When the output voltage detected by the product exceeds the threshold, it is judged to be overcurrent and the output of fault pin changes to low level .

④. the accuracy @ -40°C~105°C,  $X\_TRange = ((V_{out} - V_{ref})@ In @ T_x) - V_{oe@ 25^\circ C} - G_{th} * In) / V_{FS}$ , where  $T_x$  represents present temperature,  $G_{th}$  is fitted gain at room temperature .

## 5. Electrical performance of STK-150HO/2

$V_{cc} = 5\text{ V}$ ,  $T_A = 25^\circ\text{C}$

Parameter	Symbol	Unit	Min	Typ	Max	Comment
Primary nominal current rms	$I_{pn}$	A		150		
Primary current measuring range	$I_{pm}$	A	-375		375	
Supply voltage	$V_{cc}$	V	4.75	5	5.25	
Current consumption	$I_{cc}$	mA		6	10	
Reference voltage	$V_{ref}$	V	2.48	2.5	2.52	Output function
Electrical offset voltage @ $I_P = 0\text{ A}$	$V_{oe}$	mV	-8		8	$V_{out} - V_{ref} @ V_{ref} = 2.5\text{ V}$
Electrical offset current referred to primary	$I_{oe}$	A	-1.5		1.5	
Output voltage range @ $I_P M$	$V_{FS}$	V	-2		2	$((V_{out} - V_{ref}) @ I_{pm}) - V_{oe}$
Internal $V_{ref}$ resistance	$R_{ref}$	$\Omega$	4.5	12	19.5	Series
Internal output resistance	$R_{out}$	$\Omega$	4.5	12	19.5	Series
Difference of output resistance ( $R_{ref} - R_{out}$ )	$R_{oe}$	$\Omega$	-5		5	Series
OCD output mask time ①	$T_{mask}$	$\mu\text{s}$		2		
OCD output hold time ②	$T_{hold}$	ms		1.5		
Theoretical gain	$G$	mV/A		5.333		800 mV @ $I_P N$
Temperature drift of $V_{oe}$	$V_{oe\_TR\ range}$	mV	-10		10	$-40^\circ\text{C} \sim 105^\circ\text{C}$
Error of gain	$Err\_G$	% $G_{th}$	-0.5		0.5	Trimmed in the factory @ $25^\circ\text{C}$
Temperature drift of gain	$G\_TR$	% $G_{th}$	-1		1	@ $-40^\circ\text{C} \sim 105^\circ\text{C}$
Rated linearity error	Non- $L_{pn}$	% $I_{pn}$	-0.5		0.5	$\pm I_{pn}$
Linearity error @ $I_{pm}$	Non- $L_{pm}$	% $I_{pm}$	-1		1	$\pm I_{pm}$
Step response time	$t_{res}$	$\mu\text{s}$		1.5	2	@ 90% of $I_{pn}$
Frequency bandwidth (-3dB)	BW	kHz		200		No RC circuit
Output voltage noise	$V_{noise}$	mVpp		4.4		@140kHz Sampling Rate
Primary current, detection threshold ③	$I_{pth}$	A	$2.64 * I_{pn}$	$2.93 * I_{pn}$	$3.22 * I_{pn}$	Peak value $\pm 10\%$ overcurrent detection OCD
Accuracy @ $25^\circ\text{C}$	X	% of $I_{pn}$	-1		1	@ $25^\circ\text{C}$
Accuracy @ $-40^\circ\text{C} \sim 105^\circ\text{C}$ ④	$X_{TR\ range}$	% of $I_{pn}$	-3		3	$-40^\circ\text{C} \sim 105^\circ\text{C}$

## Remarks:

① ②. To prevent nuisance tripping, a tmask time is used. If an over current occurs, but does not persist for the duration of tmask, it does not trigger the fault pin. This prevents short transient spikes from causing erroneous fault detections. In the event where transient error reporting is desired, the tmask can be disabled. If the fault is triggered, it will remain active for a minimum time of thold and up to the end of the fault condition, whichever is greater.

③. STK-HO/2 products may be ordered on request with a dedicated setting of the Trigger current . The product has a built-in overcurrent detection function, When the output voltage detected by the product exceeds the threshold, it is judged to be overcurrent and the output of fault pin changes to low level .

④. the accuracy @ -40°C~105°C,  $X_{TRange} = ((V_{out} - V_{ref})@ \ln @ T_x) - V_{oe@ 25^{\circ}C} - G_{th} * \ln$  /  $V_{FS}$ , where  $T_x$  represents present temperature,  $G_{th}$  is fitted gain at room temperature .

## 6. Electrical performance of STK-180HO/2

$V_{cc} = 5\text{ V}$ ,  $T_A = 25^\circ\text{C}$

Parameter	Symbol	Unit	Min	Typ	Max	Comment
Primary nominal current rms	$I_{pn}$	A		180		
Primary current measuring range	$I_{pm}$	A	-450		450	
Supply voltage	$V_{cc}$	V	4.75	5	5.25	
Current consumption	$I_{cc}$	mA		6	10	
Reference voltage	$V_{ref}$	V	2.48	2.5	2.52	Output function
Electrical offset voltage @ $I_P = 0\text{ A}$	$V_{oe}$	mV	-8		8	$V_{out} - V_{ref} @ V_{ref} = 2.5\text{ V}$
Electrical offset current referred to primary	$I_{oe}$	A	-1.8		1.8	
Output voltage range @ $I_P M$	$V_{FS}$	V	-2		2	$(V_{out} - V_{ref}) @ I_{pm} - V_{oe}$
Internal $V_{ref}$ resistance	$R_{ref}$	$\Omega$	4.5	12	19.5	Series
Internal output resistance	$R_{out}$	$\Omega$	4.5	12	19.5	Series
Difference of output resistance ( $R_{ref} - R_{out}$ )	$R_{oe}$	$\Omega$	-5		5	Series
OCD output mask time ①	$T_{mask}$	$\mu\text{s}$		2		
OCD output hold time ②	$T_{hold}$	ms		1.5		
Theoretical gain	$G$	mV/A		4.444		800 mV @ $I_P N$
Temperature drift of $V_{oe}$	$V_{oe\_TR\text{ange}}$	mV	-10		10	$-40^\circ\text{C} \sim 105^\circ\text{C}$
Error of gain	$Err\_G$	% $G_{th}$	-0.5		0.5	Trimmed in the factory @ $25^\circ\text{C}$
Temperature drift of gain	$G\_TR$	% $G_{th}$	-1		1	@ $-40^\circ\text{C} \sim 105^\circ\text{C}$
Rated linearity error	Non- $L_{pn}$	% $I_{pn}$	-0.5		0.5	$\pm I_{pn}$
Linearity error @ $I_{pm}$	Non- $L_{pm}$	% $I_{pm}$	-1		1	$\pm I_{pm}$
Step response time	$t_{res}$	$\mu\text{s}$		1.5	2	@ 90% of $I_{pn}$
Frequency bandwidth (-3dB)	BW	kHz		200		No RC circuit
Output voltage noise	$V_{noise}$	mVpp		4.4		@140kHz Sampling Rate
Primary current, detection threshold ③	$I_{pth}$	A	$2.64 * I_{pn}$	$2.93 * I_{pn}$	$3.22 * I_{pn}$	Peak value $\pm 10\%$ overcurrent detection OCD
Accuracy @ $25^\circ\text{C}$	X	% of $I_{pn}$	-1		1	@ $25^\circ\text{C}$
Accuracy @ $-40^\circ\text{C} \sim 105^\circ\text{C}$ ④	$X_{TR\text{ange}}$	% of $I_{pn}$	-3		3	$-40^\circ\text{C} \sim 105^\circ\text{C}$

## Remarks:

① ②. To prevent nuisance tripping, a tmask time is used. If an over current occurs, but does not persist for the duration of tmask, it does not trigger the fault pin. This prevents short transient spikes from causing erroneous fault detections. In the event where transient error reporting is desired, the tmask can be disabled. If the fault is triggered, it will remain active for a minimum time of thold and up to the end of the fault condition, whichever is greater.

③. STK-HO/2 products may be ordered on request with a dedicated setting of the Trigger current . The product has a built-in overcurrent detection function, When the output voltage detected by the product exceeds the threshold, it is judged to be overcurrent and the output of fault pin changes to low level .

④. the accuracy @ -40°C~105°C,  $X\_TRange = ((V_{out} - V_{ref})@ In @ T_x) - V_{oe@ 25^\circ C} - G_{th} * In) / V_{FS}$ , where  $T_x$  represents present temperature,  $G_{th}$  is fitted gain at room temperature .

## 7. Electrical performance of STK-240HO/2

$V_{cc} = 5\text{ V}$ ,  $T_A = 25^\circ\text{C}$

Parameter	Symbol	Unit	Min	Typ	Max	Comment
Primary nominal current rms	$I_{pn}$	A		240		
Primary current measuring range	$I_{pm}$	A	-600		600	
Supply voltage	$V_{cc}$	V	4.75	5	5.25	
Current consumption	$I_{cc}$	mA		6	10	
Reference voltage	$V_{ref}$	V	2.48	2.5	2.52	Output function
Electrical offset voltage @ $I_P = 0\text{ A}$	$V_{oe}$	mV	-8		8	$V_{out} - V_{ref} @ V_{ref} = 2.5\text{ V}$
Electrical offset current referred to primary	$I_{oe}$	A	-2.4		2.4	
Output voltage range @ $I_P M$	$V_{FS}$	V	-2		2	$(V_{out} - V_{ref}) @ I_{pm} - V_{oe}$
Internal $V_{ref}$ resistance	$R_{ref}$	$\Omega$	4.5	12	19.5	Series
Internal output resistance	$R_{out}$	$\Omega$	4.5	12	19.5	Series
Difference of output resistance ( $R_{ref} - R_{out}$ )	$R_{oe}$	$\Omega$	-5		5	Series
OCD output mask time ①	$T_{mask}$	$\mu\text{s}$		2		
OCD output hold time ②	$T_{hold}$	ms		1.5		
Theoretical gain	$G$	mV/A		3.333		800 mV @ $I_P N$
Temperature drift of $V_{oe}$	$V_{oe\_TR\text{ange}}$	mV	-10		10	$-40^\circ\text{C} \sim 105^\circ\text{C}$
Error of gain	$Err\_G$	% $G_{th}$	-0.5		0.5	Trimmed in the factory @ $25^\circ\text{C}$
Temperature drift of gain	$G\_TR$	% $G_{th}$	-1		1	@ $-40^\circ\text{C} \sim 105^\circ\text{C}$
Rated linearity error	Non- $L_{pn}$	% $I_{pn}$	-0.5		0.5	$\pm I_{pn}$
Linearity error @ $I_{pm}$	Non- $L_{pm}$	% $I_{pm}$	-1		1	$\pm I_{pm}$
Step response time	$t_{res}$	$\mu\text{s}$		1.5	2	@ 90% of $I_{pn}$
Frequency bandwidth (-3dB)	BW	kHz		200		No RC circuit
Output voltage noise	$V_{noise}$	mVpp		4.4		@140kHz Sampling Rate
Primary current, detection threshold ③	$I_{pth}$	A	$2.64 * I_{pn}$	$2.93 * I_{pn}$	$3.22 * I_{pn}$	Peak value $\pm 10\%$ overcurrent detection OCD
Accuracy @ $25^\circ\text{C}$	X	% of $I_{pn}$	-1		1	@ $25^\circ\text{C}$
Accuracy @ $-40^\circ\text{C} \sim 105^\circ\text{C}$ ④	$X_{TR\text{ange}}$	% of $I_{pn}$	-3		3	$-40^\circ\text{C} \sim 105^\circ\text{C}$

## Remarks:

① ②. To prevent nuisance tripping, a tmask time is used. If an over current occurs, but does not persist for the duration of tmask, it does not trigger the fault pin. This prevents short transient spikes from causing erroneous fault detections. In the event where transient error reporting is desired, the tmask can be disabled. If the fault is triggered, it will remain active for a minimum time of thold and up to the end of the fault condition, whichever is greater.

③. STK-HO/2 products may be ordered on request with a dedicated setting of the Trigger current . The product has a built-in overcurrent detection function, When the output voltage detected by the product exceeds the threshold, it is judged to be overcurrent and the output of fault pin changes to low level .

④. the accuracy @ -40°C~105°C,  $X\_TRange = ((V_{out} - V_{ref})@ In @ T_x) - V_{oe@ 25^{\circ}C} - G_{th} * In) / V_{FS}$ , where  $T_x$  represents present temperature,  $G_{th}$  is fitted gain at room temperature .

## 8. Electrical performance of STK-250HO/2

$V_{CC} = 5\text{ V}$ ,  $T_A = 25^\circ\text{C}$

Parameter	Symbol	Unit	Min	Typ	Max	Comment
Primary nominal current rms	$I_{pn}$	A		250		
Primary current measuring range	$I_{pm}$	A	-625		625	
Supply voltage	$V_{CC}$	V	4.75	5	5.25	
Current consumption	$I_{CC}$	mA		6	10	
Reference voltage	$V_{ref}$	V	2.48	2.5	2.52	Output function
Electrical offset voltage @ $I_P = 0\text{ A}$	$V_{oe}$	mV	-8		8	$V_{out} - V_{ref} @ V_{ref} = 2.5\text{ V}$
Electrical offset current referred to primary	$I_{oe}$	A	-2.5		2.5	
Output voltage range @ $I_P M$	$V_{FS}$	V	-2		2	$(V_{out} - V_{ref}) @ I_{pm} - V_{oe}$
Internal $V_{ref}$ resistance	$R_{ref}$	$\Omega$	4.5	12	19.5	Series
Internal output resistance	$R_{out}$	$\Omega$	4.5	12	19.5	Series
Difference of output resistance ( $R_{ref} - R_{out}$ )	$R_{oe}$	$\Omega$	-5		5	Series
OCD output mask time ①	$T_{mask}$	$\mu\text{s}$		2		
OCD output hold time ②	$T_{hold}$	ms		1.5		
Theoretical gain	$G$	mV/A		3.2		800 mV @ $I_P N$
Temperature drift of $V_{oe}$	$V_{oe\_TR\text{ange}}$	mV	-10		10	$-40^\circ\text{C} \sim 105^\circ\text{C}$
Error of gain	$Err\_G$	% $G_{th}$	-0.5		0.5	Trimmed in the factory @ $25^\circ\text{C}$
Temperature drift of gain	$G\_TR$	% $G_{th}$	-1		1	@ $-40^\circ\text{C} \sim 105^\circ\text{C}$
Rated linearity error	Non- $L_{pn}$	% $I_{pn}$	-0.5		0.5	$\pm I_{pn}$
Linearity error @ $I_{pm}$	Non- $L_{pm}$	% $I_{pm}$	-1		1	$\pm I_{pm}$
Step response time	$t_{res}$	$\mu\text{s}$		1.5	2	@ 90% of $I_{pn}$
Frequency bandwidth (-3dB)	BW	kHz		200		No RC circuit
Output voltage noise	$V_{noise}$	mVpp		4.4		@140kHz Sampling Rate
Primary current, detection threshold ③	$I_{pth}$	A	$2.64 * I_{pn}$	$2.93 * I_{pn}$	$3.22 * I_{pn}$	Peak value $\pm 10\%$ overcurrent detection OCD
Accuracy @ $25^\circ\text{C}$	X	% of $I_{pn}$	-1		1	@ $25^\circ\text{C}$
Accuracy @ $-40^\circ\text{C} \sim 105^\circ\text{C}$ ④	$X_{TR\text{ange}}$	% of $I_{pn}$	-3		3	$-40^\circ\text{C} \sim 105^\circ\text{C}$

Remarks:

① ②. To prevent nuisance tripping, a tmask time is used. If an over current occurs, but does not persist for the duration of tmask, it does not trigger the fault pin. This prevents short transient spikes from causing erroneous fault detections. In the event where transient error reporting is desired, the tmask can be disabled. If the fault is triggered, it will remain active for a minimum time of thold and up to the end of the fault condition, whichever is greater.

③. STK-HO/2 products may be ordered on request with a dedicated setting of the Trigger current . The product has a built-in overcurrent detection function, When the output voltage detected by the product exceeds the threshold, it is judged to be overcurrent and the output of fault pin changes to low level .

④. the accuracy @ -40°C~105°C,  $X_{TRange} = ((V_{out} - V_{ref})@ I_n @ T_x) - V_{oe@ 25^\circ C} - G_{th} * I_n) / V_{FS}$ , where  $T_x$  represents present temperature,  $G_{th}$  is fitted gain at room temperature .

### 9. Output voltage VS primary current of STK-HO/2

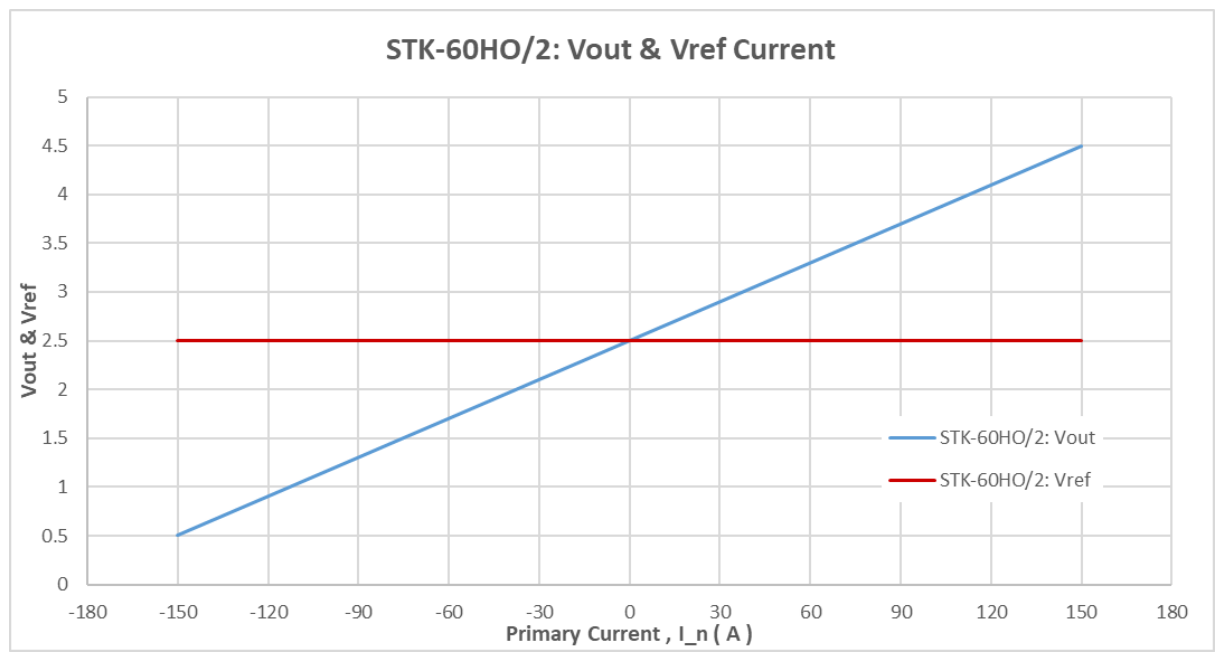

The dependence of Vout & Vref of STK-60HO/2 on the primary current.

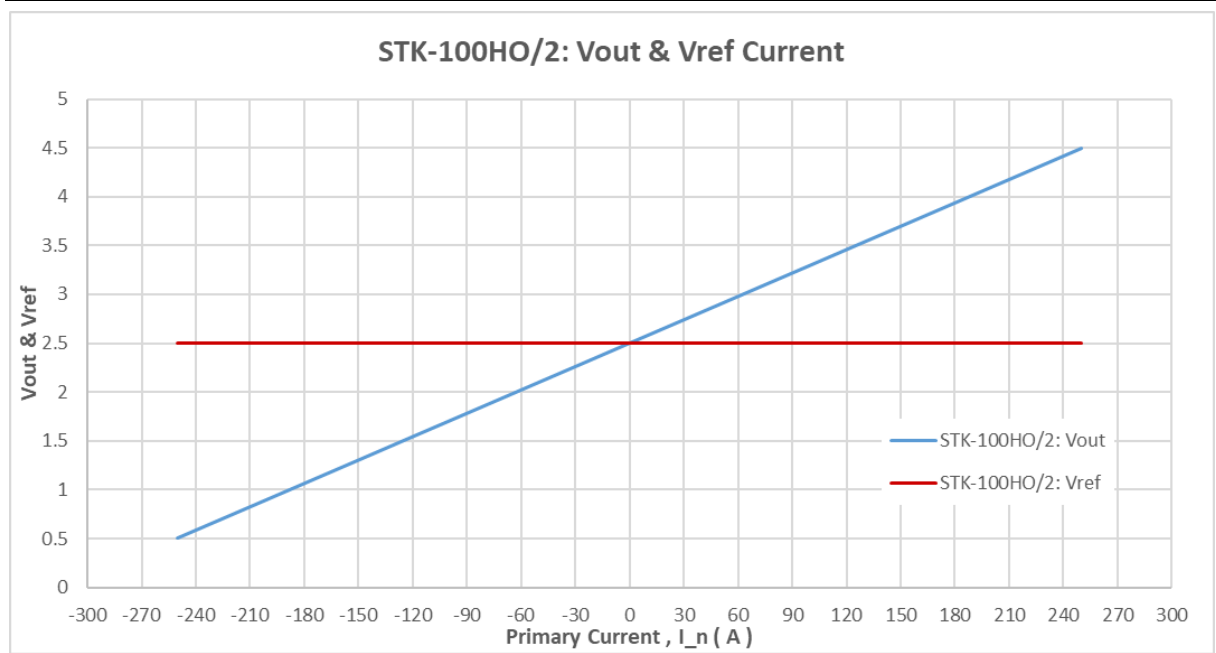

The dependence of Vout & Vref of STK-100HO/2 on the primary current.

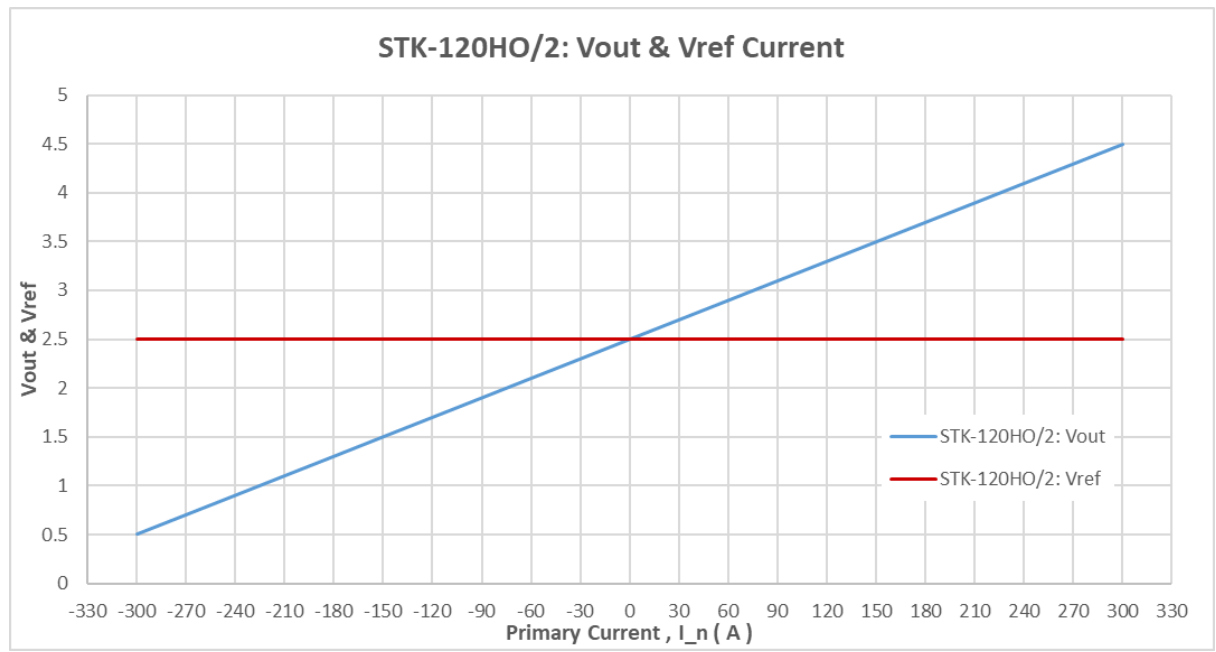

The dependence of Vout & Vref of STK-120HO/2 on the primary current.

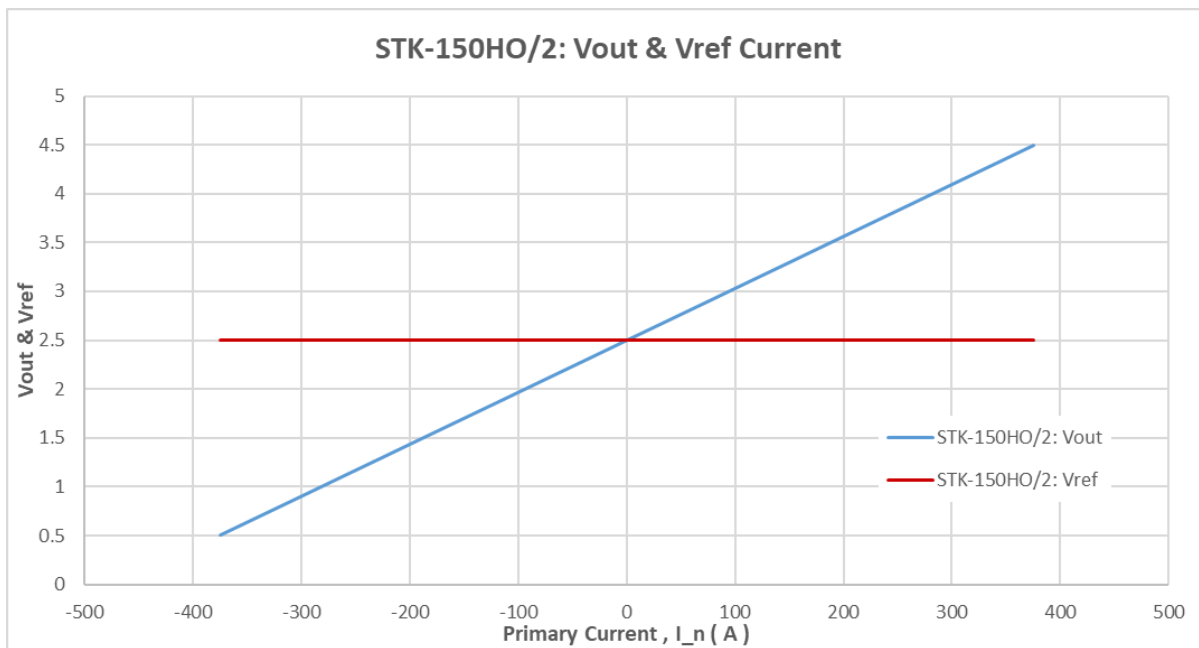

The dependence of Vout & Vref of STK-150HO/2 on the primary current.

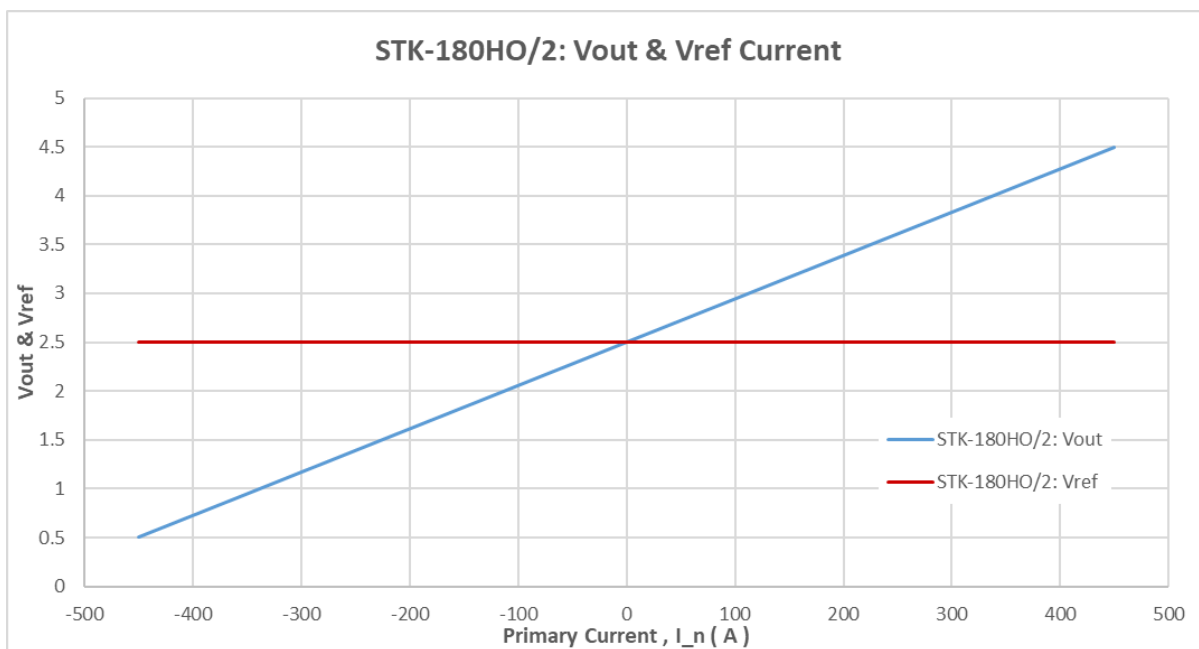

The dependence of Vout & Vref of STK-180HO/2 on the primary current.

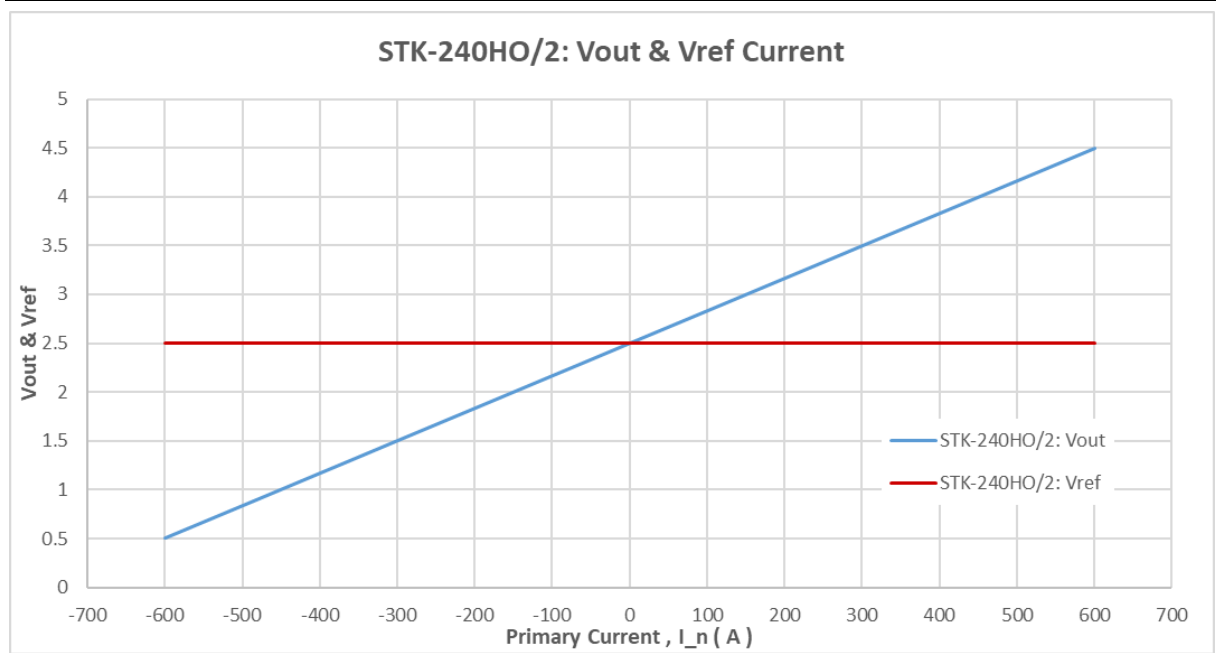

The dependence of Vout & Vref of STK-240HO/2 on the primary current.

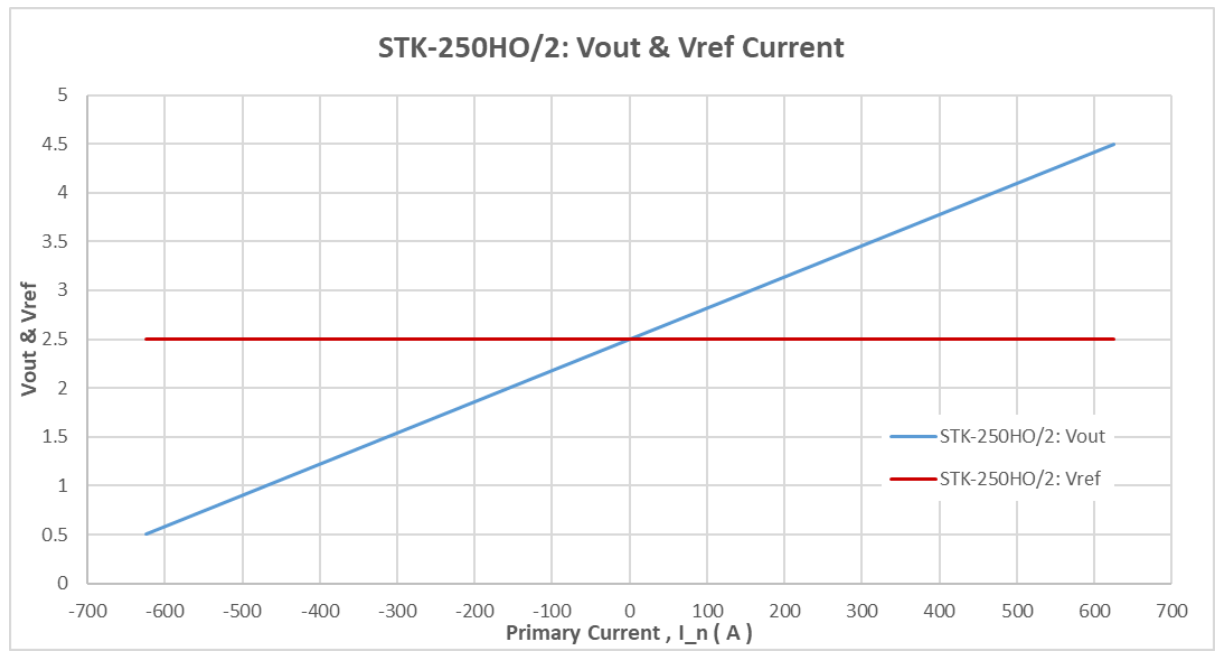

The dependence of Vout & Vref of STK-250HO/2 on the primary current.

### 10. Frequency bandwidth

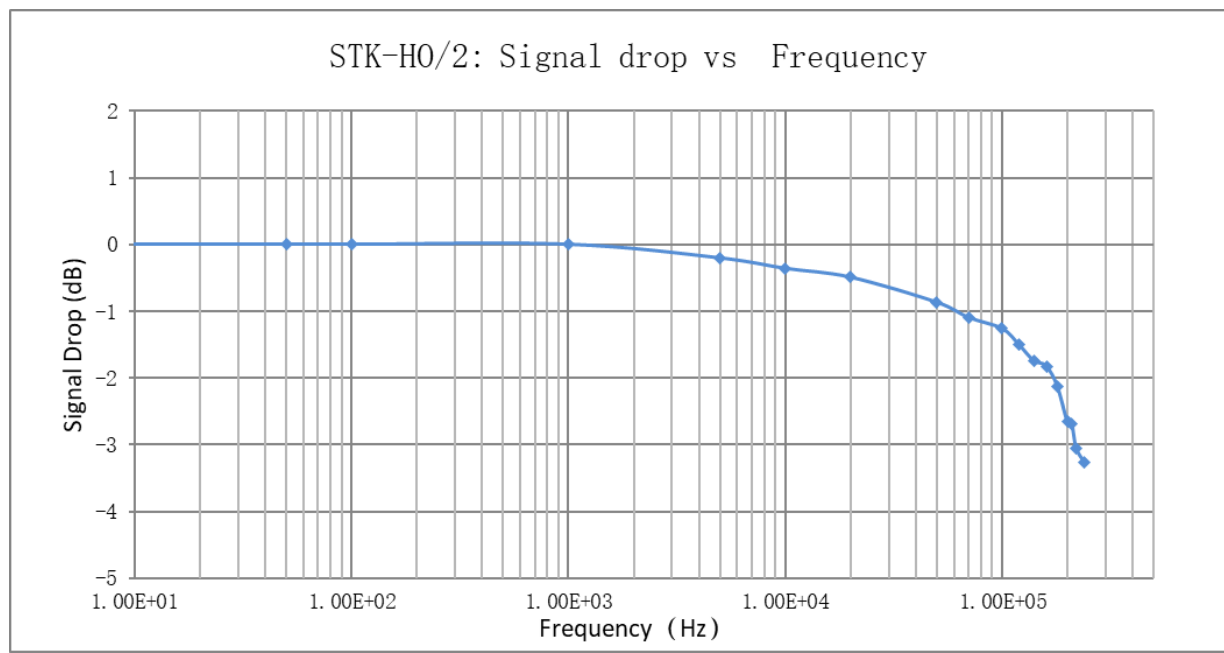

The frequency band width of STK-HO/2 series current sensors.

### 11. Step response time

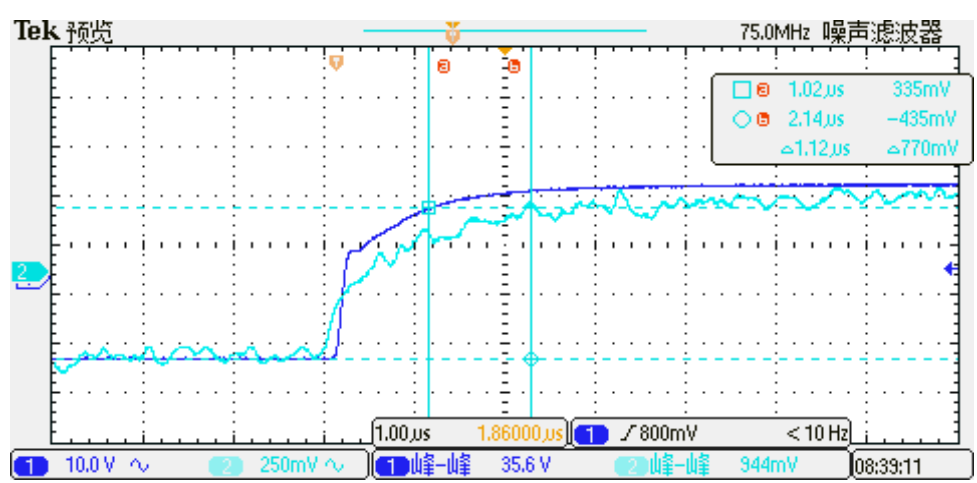

The step response time of STK-HO/2 current sensors. The dark light blue is primary current, while the light blue is output signal of current sensor. The step response time is about 1.12 μs.

## 12. PCB Footprint in mm

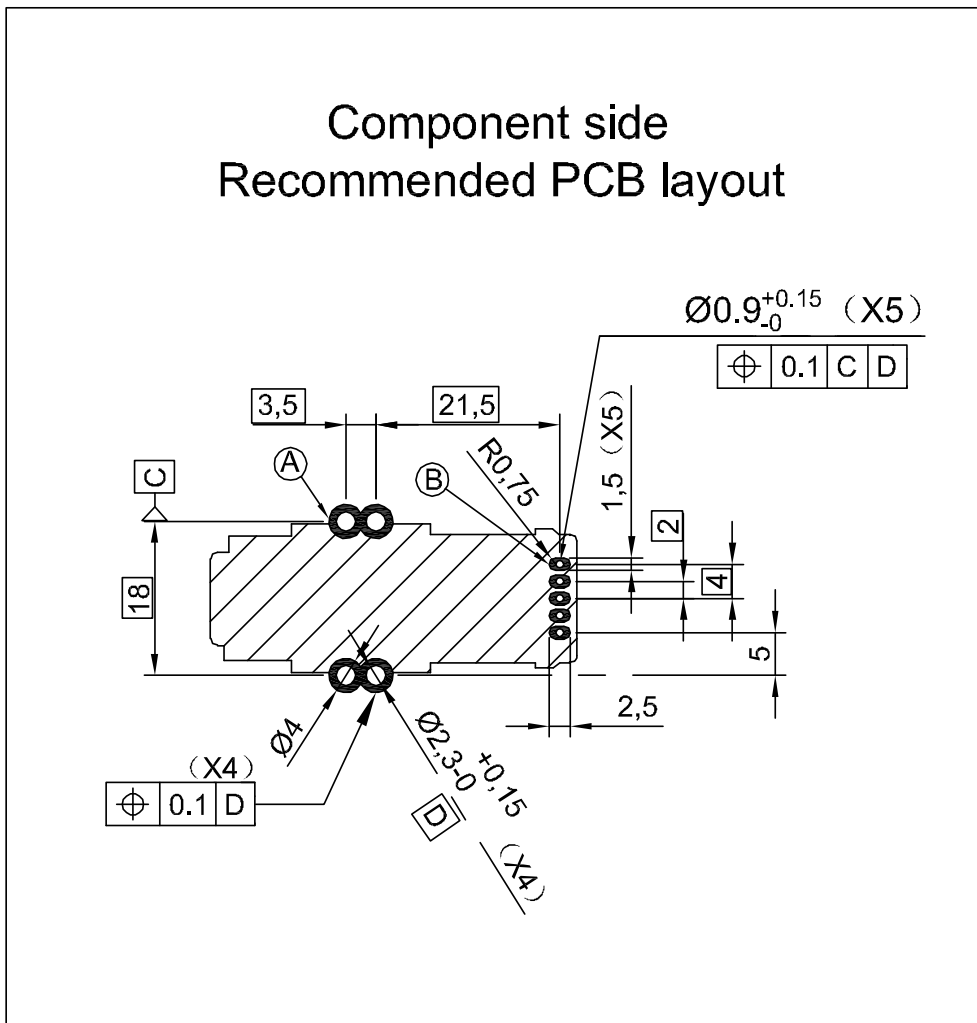

Assembly on PCB:

Recommended PCB hole diameter	2.15 mm for primary pin 0.9 mm for secondary pin
Maximum PCB thickness	2.4 mm
Wave soldering profile	maximum 260 °C, 10 s
No clean process only	

Insulation distance (nominal values):

	$d_{cp}$	$d_{ci}$
On PCB: A - B	18.85 mm	-
Between jumper and secondary pin	21.1 mm	20.9 mm
Between primary busbar and secondary pin	14.6 mm	-
Between primary busbar and jumper	-	8 mm
Between primary busbar and core	-	11.34 mm
Between core and secondary terminal	-	1.18 mm

### 13. Dimensions & Pins & Footprint

NOTES:

- 1) MATERIAL  
Primary: Copper alloy  
Secondary: Phosphorous bronze
- 2) PLATING  
Terminals : Tin over Nickel
- 3) PRODUCT MARKING  
See drawing
- 4) CUSTOMER MOUNTING  
See recommended PCB layout

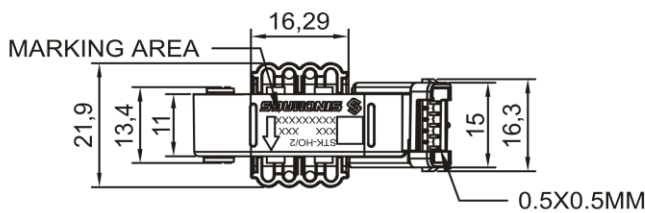
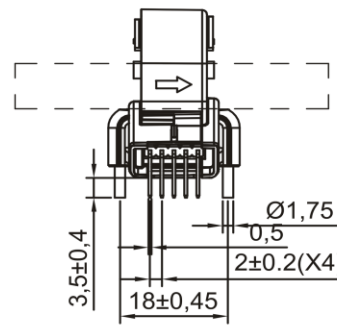
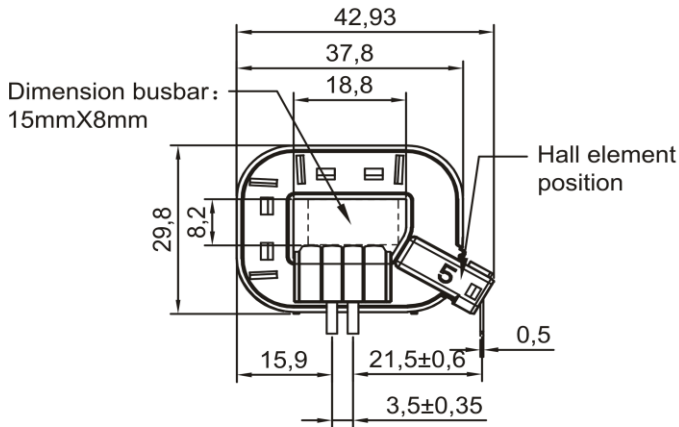
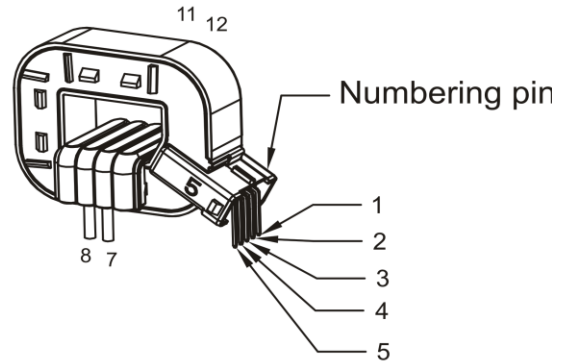

Connection

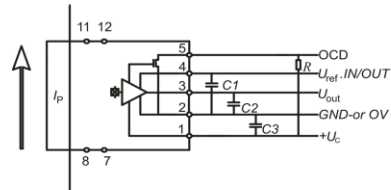

	dCl(mm)	dCp(mm)
A-B	18.85	18.85

C1	47nF
C2	4.7nF
C3	47 nF
R	5.1KΩ

Material : Fit UL94V-0 & RoHS requirements ;  
General tolerance : ±0.5  
Unit :mm

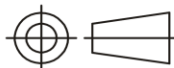

## 14. General information on OCD

This section describes the general information on OCD function, the specific functions, which are not listed in the section of "electrical data", can be defined per request.

Since the trigger voltage is set after the second amplifier, the OCD function supports that the trigger current can be higher than  $I_{pn}$ . The trigger voltage can be defined:

- a)  $V_{ref} = 2.5\text{ V}$
- b)  $0.5\text{ V} \leq V_{OC} \leq V_{ref}$ ;
- c) Trigger voltage =  $V_{ref} \pm V_{OC}$ ;
- d) Trigger current =  $(V_{ref} \pm V_{OC} - V_{off}) / G_{th}$ ;

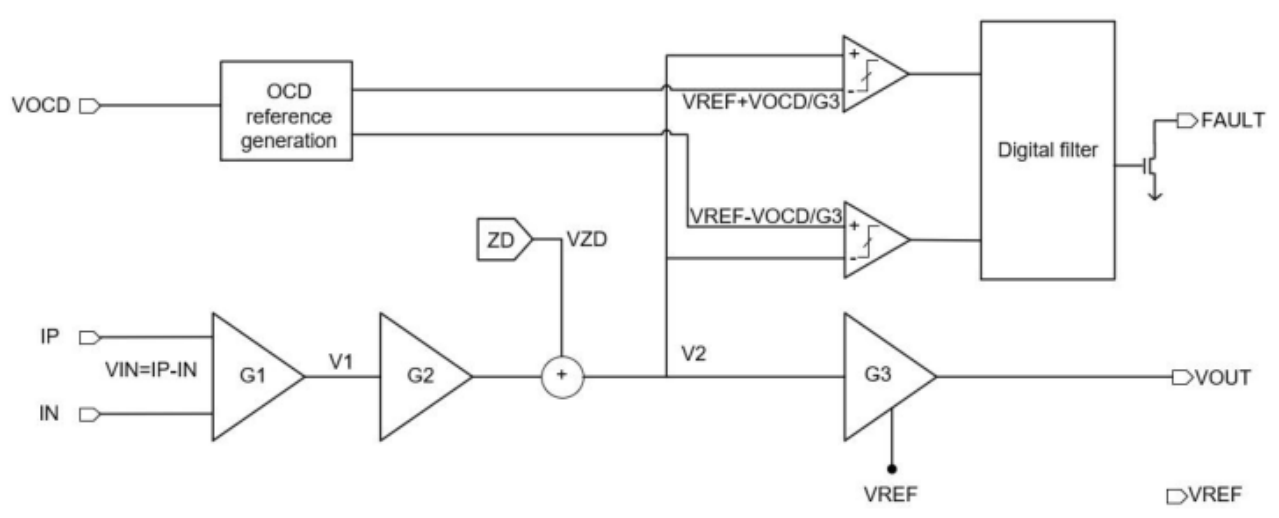

Functional Block Diagram on OCD function when  $V_{ref} = 2.5\text{ V}$

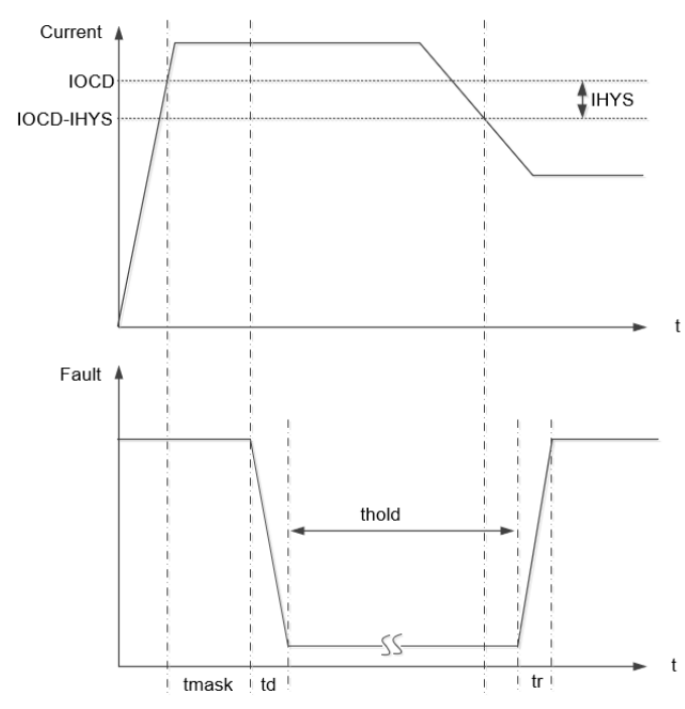

The above plot shows the definition on the time in OCD function. The typical value for tmask & thold is that tmask = 2 $\mu$ s , and thold = 1.5ms . The overcurrent detection function can also set tmask and thold time:

a)

Tmask:set	Value
1	0 $\mu$ s
2	1 $\mu$ s
3	2 $\mu$ s
4	3 $\mu$ s

Thold:set	Value
1	0ms
2	1.5ms
3	3ms
4	4.5ms