

## Current Sensor

---

Product Series: STK-HO/B

Part number: STK-50HO/B,  
STK-75HO/B,  
STK-100HO/B,  
STK-130HO/B,  
STK-180HO/B,  
V1.2

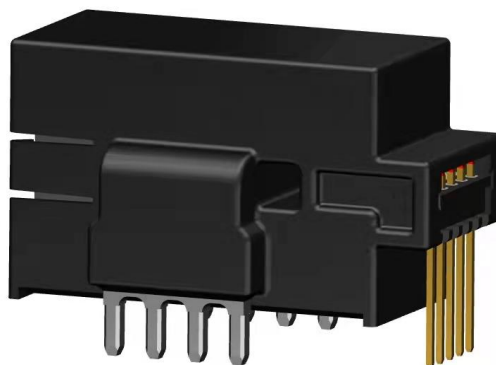

Sinomags Technology Co., Ltd

Web site: [www.sinomags.com](http://www.sinomags.com)

## CONTENT

CONTENT .....	1
1. Summary .....	2
2. STK-H0/B Electrical performance .....	4
3. Output voltage VS primary current .....	6
4. Frequency bandwidth .....	6
5. Step response time .....	7
6. Dimension & Pin definitions .....	8
7. Solder Line chart .....	9

## 1. Summary

The STK-H0/B series is based on open-loop design. It is suitable for DC, AC, pulsed and any kind of irregular current measurement under the isolated conditions. The nominal current range of the STK-H0/B current sensor consists of 50 A, 75 A, 100 A, 130 A, 180A.

### Typical applications

- AC variable speed and servo motor drives
- Static converters for DC motor drives
- Battery supplied applications
- Uninterruptible Power Supplies (UPS)
- Switched Mode Power Supplies (SMPS)
- Combiner box
- Solar inverter on DC side of the inverter (MPPT)
- Plasma cutter, welding
- Charging station.

### General parameter

Parameter	Symbol	Unit	Value
Working temperature	T <sub>A</sub>	°C	-40 ~ 105
Storage temperature	T <sub>stg</sub>	°C	-40 ~ 105
Mass	m	g	35

### Absolute maximum rating

Parameter	Symbol	Unit	Value
Supply voltage (non-destructive)	V <sub>C</sub>	V	6
ESD rating (HBM)	U <sub>ESD</sub>	kV	4

Remark: the unrecoverable damage may occur when the product works on the conditions over the absolute maximum ratings. Long-time working on the absolute maximum ratings may cause the degradation on performance and reliability.

**Isolation parameter**

Parameter	Symbol	Unit	Value	Comment
RMS voltage for AC test 50Hz/1 min	Ud	kV	4	@ 50Hz/1 min
Impulse withstand voltage 1.2/50μs	Ūw	kV	8	1.2/50μs
Clearance distance (pri. -sec)	dCl	mm	11.6	Shortest distance through air
Creepage distance (pri. -sec)	dCp	mm	11.6	Shortest path along device body
Case material			V0	According to UL 94
Application example	CTI	V	600	Reinforced insulation, CAT III, PD 2, non uniform field according EN 50178, IEC 61010

## 2. STK-H0/B Electrical performance

Condition:  $T_A = 25^\circ\text{C}$ ,  $V_{CC} = 5\text{ V}$  (Except special instructions)

Parameter	Symbol	Unit	Min	Typ	Max	Comment
Primary nominal current rms	$I_{pn}$	A		50		STK-50HO/B
				75		STK-75HO/B
				100		STK-100HO/B
				130		STK-130HO/B
				180		STK-180HO/B
Primary current measuring range	$I_{pm}$	A	-125		125	STK-50HO/B
			-187.5		187.5	STK-75HO/B
			-250		250	STK-100HO/B
			-325		325	STK-130HO/B
			-350		350	STK-180HO/B
Supply voltage	$V_{CC}$	V	4.75	5	5.25	
Current consumption	$I_{CC}$	mA	5	7	9	
Reference voltage	$V_{ref}$	V	2.48	2.5	2.52	Output function
Rated output voltage	$V_{FS}$	V		0.8		$(V_{out} - V_{ref}) @ I_{pn}$
Internal output resistance	$R_{out}$	$\Omega$	15	20	25	Output
Internal output resistance	$R_{ref}$	$\Omega$	12	16	20	$V_{ref}$
Quiescent voltage	$V_{off}$	V	2.48	2.5	2.52	$V_{out} @ 0\text{ A}$
Electrical offset voltage	$V_{oe}$	mV	-10		10	$(V_{out} - V_{ref}) @ 0\text{ A}$
Temperature drift of $V_{oe}$	$V_{oe\_TRange}$	% $V_{FS}$	-1.5		1.5	$-40^\circ\text{C} \sim 105^\circ\text{C}$
Theoretical gain	$G_{th}$	mV/A		16		STK-50HO/B
				10.666		STK-75HO/B
				8		STK-100HO/B
				6.154		STK-130HO/B
				4.444		STK-180HO/B
Rated linearity error	Non- $L_{pn}$	% $I_{pn}$	-0.5		0.5	$\pm I_{pn}$
Linearity error @ $I_{pm}$	Non- $L_{pm}$	% $I_{pm}$	-1		1	STK-50HO/B
			-1		1	STK-75HO/B
			-1		1	STK-100HO/B
			-3		3	STK-130HO/B
			-10		10	STK-180HO/B
Step response time	$t_{res}$	$\mu\text{s}$		0.2		@ 90% of $I_{pn}$
Frequency bandwidth (-3dB)	BW	kHz		1000		No RC circuit
Output voltage noise DC ~ 10 kHz	$V_{noise}$	mVpp		15		

DC ~ 100 kHz				25		
Accuracy @ 25°C	X	% of I <sub>pn</sub>	-1		1	@ 25°C
Accuracy @ -40°C ~ 105°C	X_TRange	% of I <sub>pn</sub>	-3		3	-40°C ~ 105°C

### 3. Output voltage VS primary current

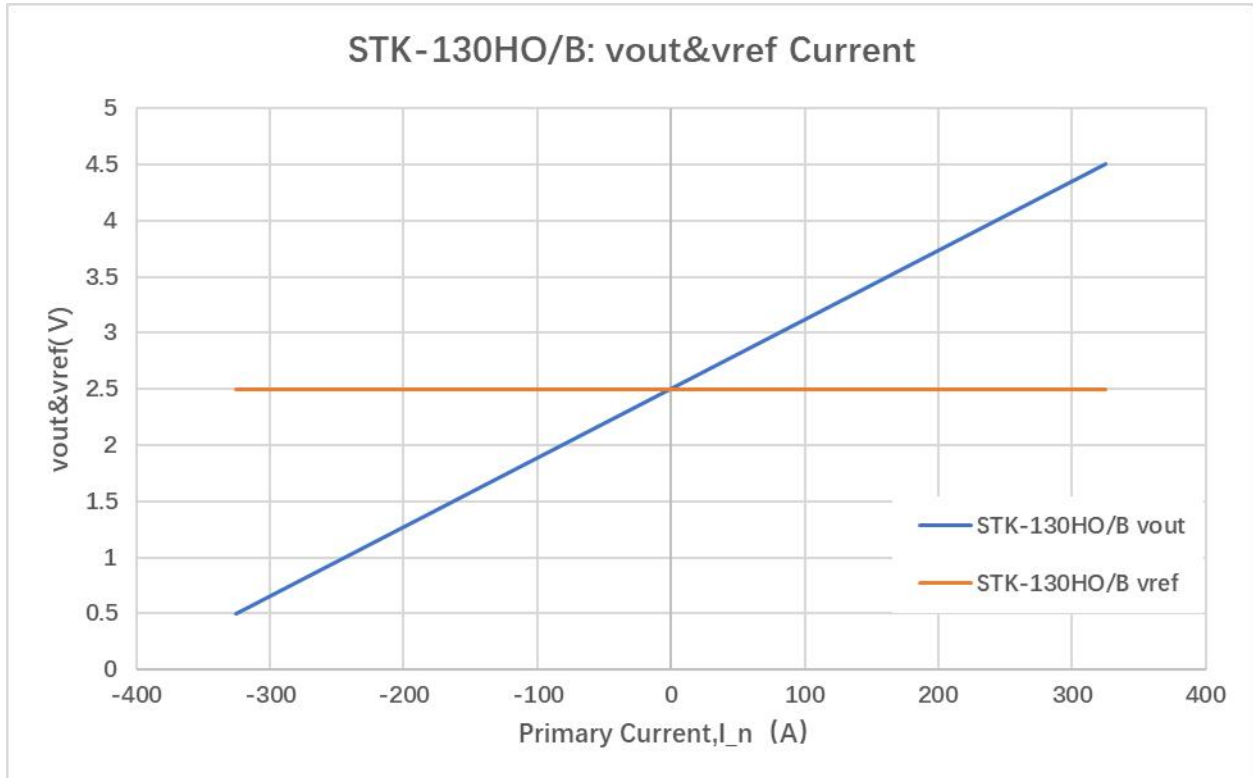

The dependence of Vout of STK-130HO/B on the primary current.

### 4. Frequency bandwidth

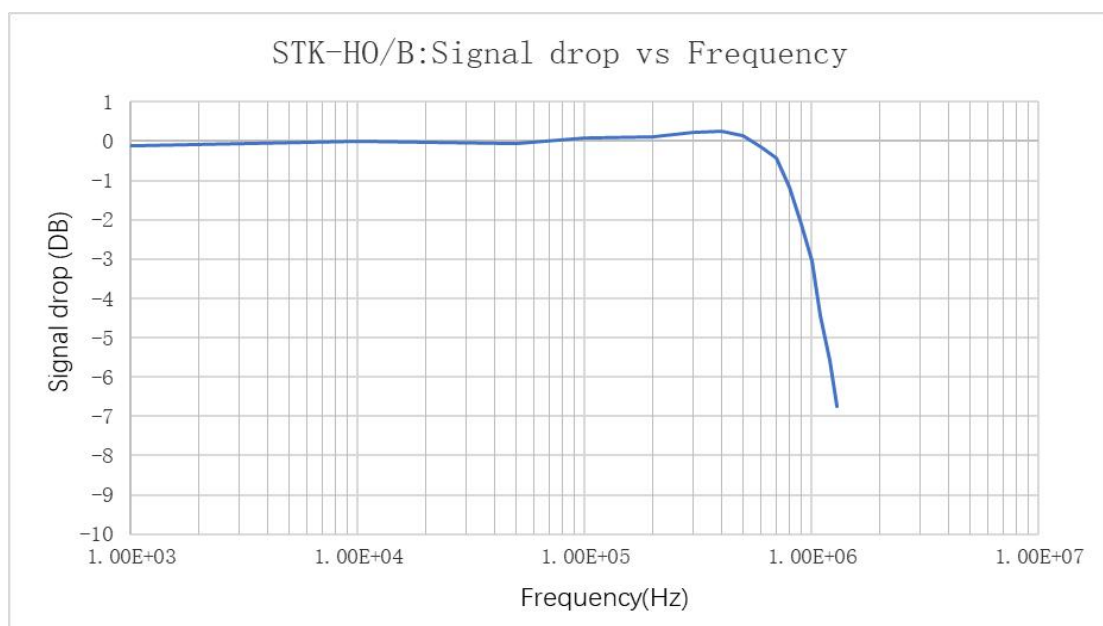

The frequency bandwidth of STK-H0/B series current sensor. The bandwidth of current sensor is DC ~ 1000 kHz (-3dB).

## 5. Step response time

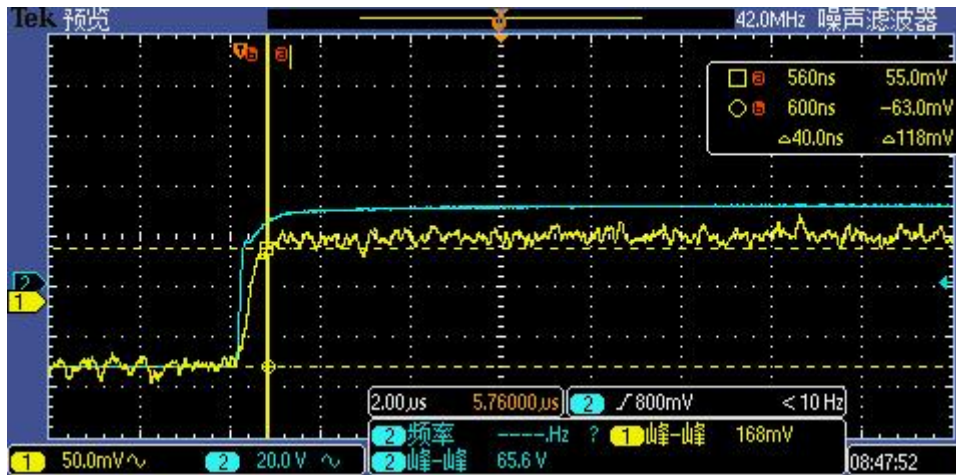

The typical frequency response of STK-H0/B current sensor. The response time from 90% of the primary current (light blue) to 90% of the secondary output (yellow) is less than 0.2 μs.

## 6. Dimension & Pin definitions

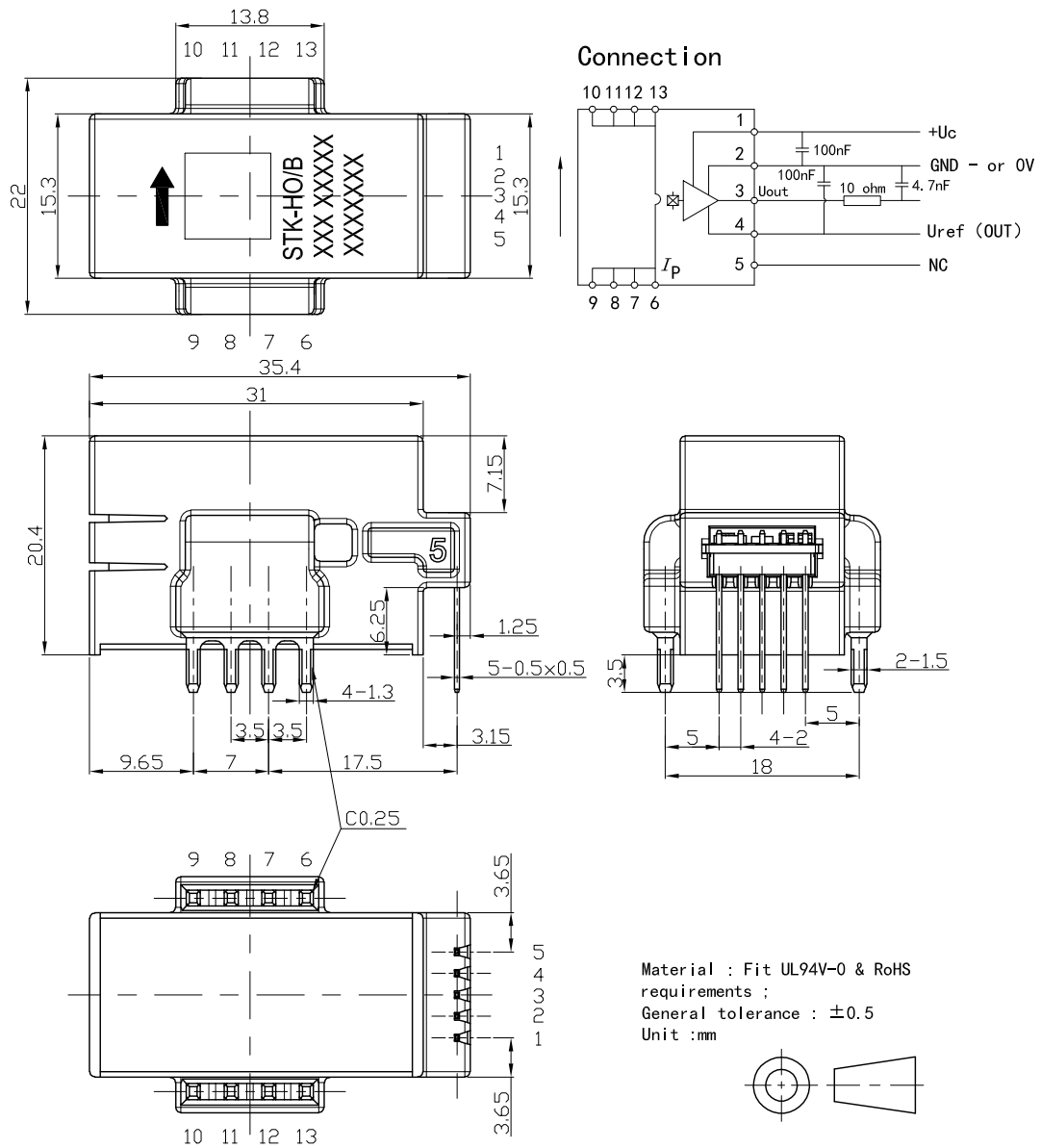



编写	审核	版本	修订内容	修订日期
张纯涛	谢建勇	V1.0	STK-H0/B 初版发行	2022-06-20
张纯涛	谢建勇	V1.1	增加 180A 量程	2023-06-10
张纯涛	谢建勇	V1.2	增加推荐焊盘和焊接曲线	2025-10-09