

CURRENT SENSOR

PRODUCT SERIES: SFG-X.XCPL/A
PRODUCT PART NUMBER: SFG-0.3CPL/A4
REVISION: Ver 1.2



CONTENT

1.	Description	2
2.	Absolute parameter	3
3.	Electrical data	4
4.	Application information	5
5.	Dimensions (in mm)	7

1. Description

Features

- High and low level output
- Single supply voltage
- Self-check function
- Cobalt base magnetic ring.

Advantages

- Stable accuracy
- Low hysteresis
- Short response time
- Compact design

Applications

- Ground fault detection
- Converter leakage current detection
- Electric vehicle charge station
- IC-CPD
- Wallbox

Standards

- EN 50178
- IEC 62752 IEC62955
- IEC 61851
- UL1741 UL508 UL94-V0

2. Absolute parameter

Absolute maximum ratings

Parameter	Symbol	Unit	Min	Typ	Max
Supply voltage	V _c	V			5.5
Ambient operating temperature	T _A	°C	-40		105
Ambient storage temperature	T _A	°C	-40		105

Stresses above these ratings may cause permanent damage. Exposure to absolute maximum ratings for extended periods may degrade reliability.

Isolation parameters

Parameter	Symbol	Unit	Value
RMS voltage for AC test 50Hz/1min	V _d	kV	3
Impulse withstand voltage 1.2/50μs	V _w	kV	7
Lightning surge current 8/20μs	I _{LS}	kA	5
Comparative tracking index	CTI	V	600
Application example	-	V	600,CAT III,PD2

3. Electrical data

at $T_A = 25^\circ\text{C}$, $V_C = 5\text{ V}$.

Parameters	Symbol	Unit	Min	Typ	Max	Remark
Supply voltage	V_C	V	4.9	5	5.1	
Current consumption	I_C	mA		25	30	
Output voltage (Check function)	V_{CK}	V		V_C		
Check current	I_{CK}	mA		30		
Check enable voltage	V_{CE}	V	3.3		V_C	
Check disabled voltage	V_{CD}	V		< 0.2		
Power on initialization	t_{on}	ms			60	
Primary nominal RMS current	I_M	A		20		

4. Application information

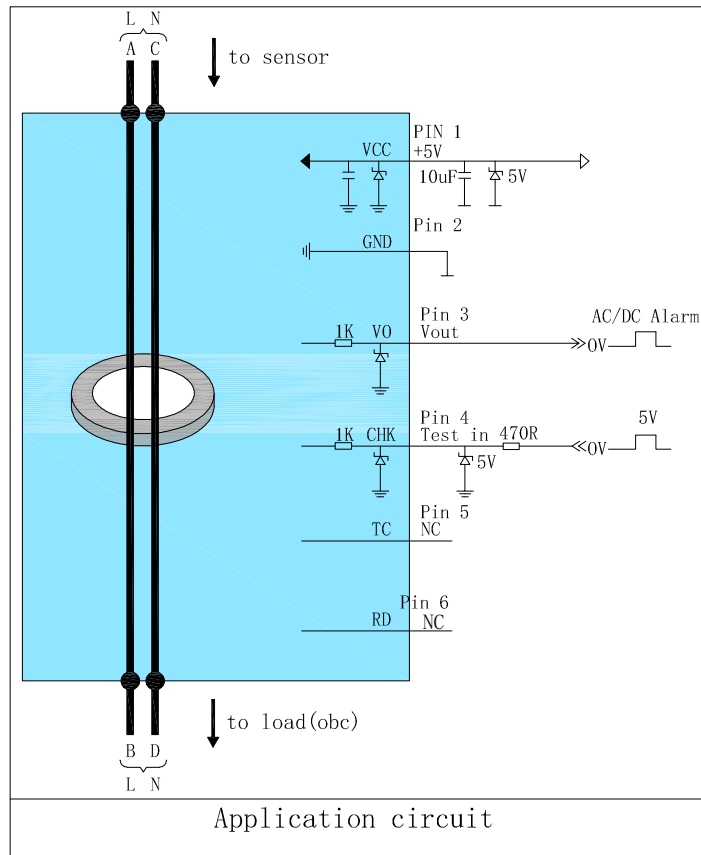

Self-check Function

When the main circuit is not working, the system leakage current is 0, the V_{out} = Low level (0v).
 (a) .when the CHK PIN is placed at high level (3.3~5V), V_{out} rises from Low level to high level(V_{cc});
 (b) .when the CHK PIN is placed at low level (< 0.2V), the self-generated the V_{out} drops to Low level (0v).
 When the above (a) and (b) are completed, the leakage current sensor is judged to have normal function.
 When the self-check function is not used, add a 0Ω resistance to the CHK PIIN and ground it.

Self-check Timing Diagram

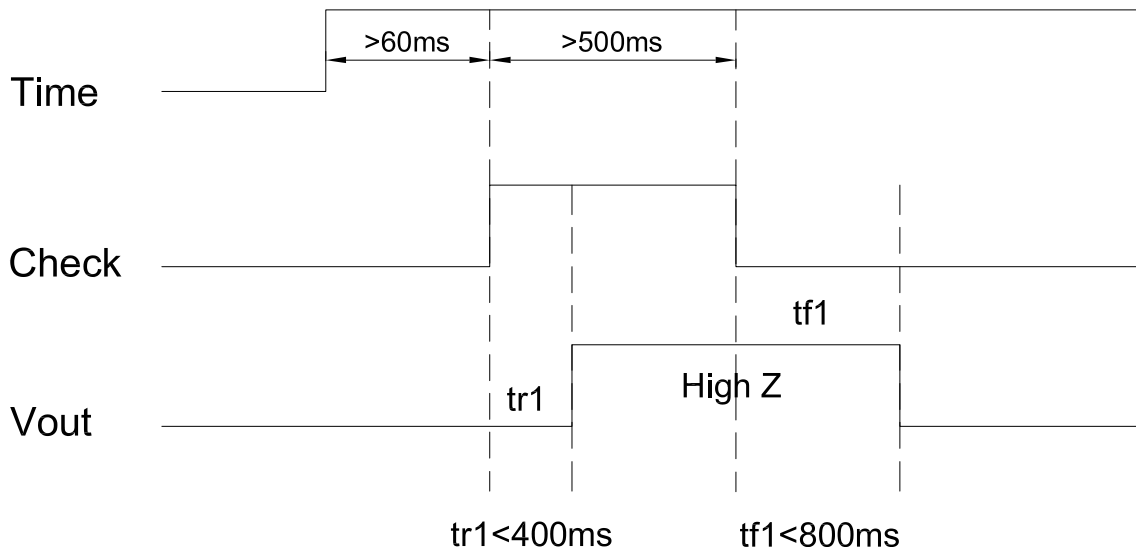

Interrupting Time (IEC62752)

Interrupting Time (IEC62752)

I Δ n=10mA

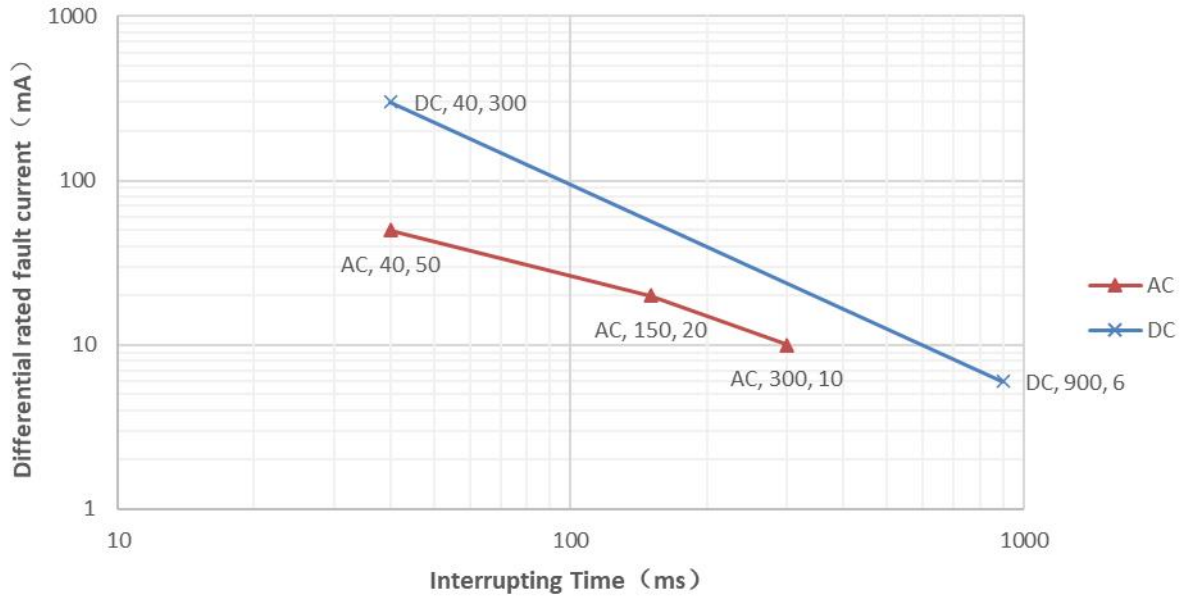

Interrupting Time (IEC62752)

I Δ n=30mA

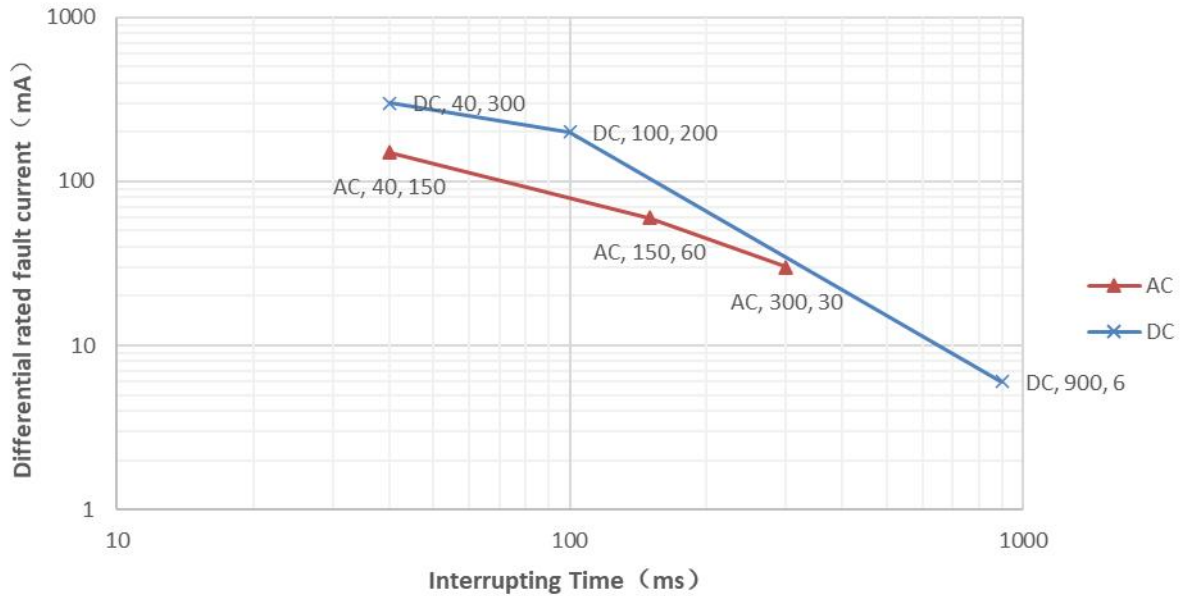

5. Dimensions (in mm)

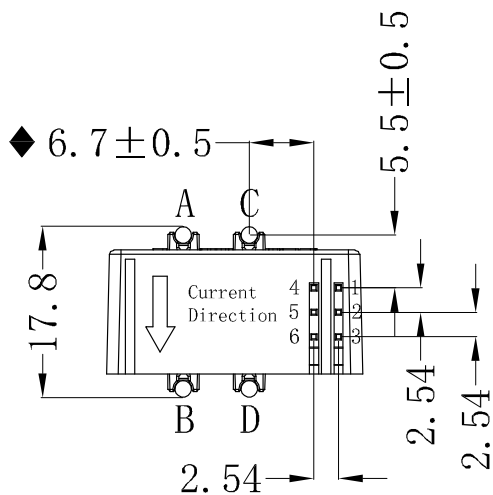
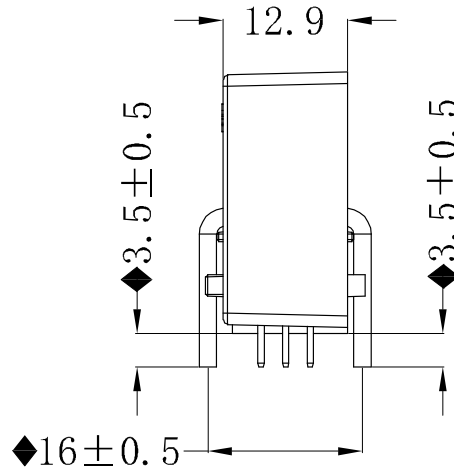
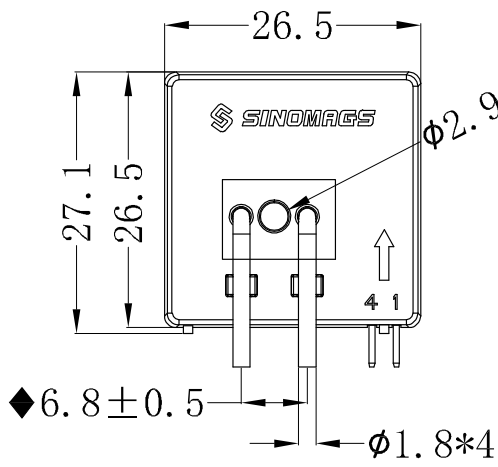

No.	Symbol	Description
1	VCC	Power supply
2	GND	Power GND
3	VO	High and low level output
4	CHK	Product Self-Check input
5	TC	NC-Float
6	RD	Version Conversion(①&②)*
A-D	IP	Primary Current

Material : Fit UL94V-0 & RoHS requirements ;
 General tolerance : ±0.5
 Unit :mm

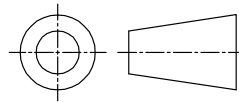

Pin Definition

No.	Symbol	Description
1	VCC	Power supply
2	GND	Power GND
3	Vo	High and low level output
4	CHK	Product Self-Check input
5	TC	NC-Float
6	RD	Version Conversion(①&②)*
A-D	IP	Primary Current

*Note:①:The default version(I△30mA);

②:Connect 1K resistance to ground version (I△10mA).

履历:

V1.0 初版

V1.1 datasheet 增加脱扣参数细节判断

V1.2 变更丝印内容: SFG-0.3CPL/A4S