

CURRENT SENSOR

PRODUCT SERIES: SFG-X.XP/P2F

PRODUCT PART NUMBER: SFG-0.3P/P2F, SFG-0.6P/P2F,
SFG-1.0P/P2F, SFG-1.5P/P2F,
SFG-2.0P/P2F, SFG-3.0P/P2F.

Version: Ver2.0

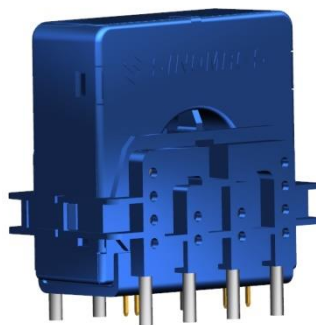

S Technology Co., Ltd

Web site: www.sinomags.com

CONTENT

1.	Description	2
2.	Absolute parameter	3
3.	Electrical data: SFG-0.3P/P2F	5
4.	Electrical data: SFG-0.6P/P2F	7
5.	Electrical data: SFG-1.0P/P2F	9
6.	Electrical data: SFG-1.5P/P2F	11
7.	Electrical data: SFG-2.0P/P2F	12
8.	Electrical data: SFG-3.0P/P2F	14
9.	PCB footprint	15
10.	Dimensions	17

1. Description

Features

- Closed loop (compensated) current transducer
- Voltage output
- Insulation voltage for 5 kVAC
- Single supply voltage

Advantages

- High accuracy
- High overload capability
- High insulation capability
- High separation ability
- Low temperature drift
- Degauss and test functions

Applications

- Residual current measurement
- Leakage current measurement in PV inverters
- First human contact protection of PV arrays
- Failure detection in power sources
- Leakage current detection in stacked DC sources
- Communication power

2. Absolute parameter

Absolute maximum ratings

Parameter	Symbol	Unit	Value
Maximum Supply voltage	$V_{C \max}$	V	7
Maximum Primary conductor temperature	$T_{B \max}$	°C	110
Maximum overload capability (100 μ s, 500 A/ μ s)	$\hat{I}_{P \max}$	A	3300

Ratings

Parameter	Symbol	Unit	Value
Primary involved potential		V AC/DC	1000
Max surrounding air temperature	T_A	°C	105
Secondary supply voltage	U_C	V DC	5
Output voltage	V_{out}	V	0 to 5

Isolation parameters

Parameter	Symbol	Unit	Value	Remark
RMS voltage for AC test 50Hz/1 min	V_d	kV	4	
Impulse withstand voltage 1.2/50 μ s	V_w	kV	10.1	
Clearance distance (pri. –pri.)	d_{Cl}	mm	6.7	Shortest distance through air
Creepage distance (pri. – pri.)	d_{Cp}	mm	7.7	Shortest path along device body
Clearance distance (pri. –sec.)	d_{Cl}	mm	5.6	Shortest distance through air
Creepage distance (pri. –sec.)	d_{Cp}	mm	5.6	Shortest path along device body
Comparative tracking index	CTI	V	600	
Application example	-	V	600 CAT III, PD2	Reinforced insulation, non uniform field

Application example	-	V	1000 CAT III, PD2	Basic insulation, non uniform field
---------------------	---	---	----------------------	-------------------------------------

Environmental and mechanical characteristics

Parameter	Symbol	Unit	Min	Typ	Max	Comment
Ambient operating temperature	T _A	°C	-40		105	
Ambient storage temperature	T _S	°C	-40		105	
Mass	m	g		80		
standard	EN 50178, IEC 61010, UL 508					

3. Electrical data: SFG-0.3P/P2F

At $T_A = 25\text{ }^\circ\text{C}$, $V_C = 5\text{ V}$.

Parameters	Symbol	Unit	Min	Typ	Max	Remark
Primary nominal residual rms current	I_{PN}	A		0.3		
Primary residual current, measuring range	I_{PM}	A	-0.5		0.5	
Supply voltage	V_C	V	4.75	5	5.25	
Current consumption	I_C	mA		17.5	21.6	$I_P(\text{mA}) / N_a$ $N_a = 1000\text{ turns}$ - 40°C ...105°C
Output voltage referred to V_{ref} (Test current)	V_{out}	V	0.7	1.2	1.7	
Reference voltage @ $I_P = 0$	V_{ref}	V	2.495	2.5	2.505	Internal reference
External reference voltage	V_{REF}	V	2.3		4	Internal reference of V_{ref} input = 499 Ω
Electrical offset current referred to primary	I_{OE}	mA	-24	7	24	
Temperature coefficient of VOE @ $I_P = 0$	TCV_{OE}	ppm/K			± 570	ppm/K of 2.5 V -40 ... 105 °C
Theoretical sensitivity	G_{th}	V/A		4		
Sensitivity error	ϵ_G	%	-1.6	0.5	1.6	$R_L > 500\text{ k}\Omega$
Temperature coefficient of G	TCG	ppm/K			± 400	- 40°C ...105°C
Linearity error	ϵ_L	%		0.5	1	
Check current	I_{CK}	mA		50		10%
Output voltage(Check function)	V_{CK}	V		VOS+0.2		

Check enable voltage	V_{CE}	V	3.3		V_C	
Check disabled voltage	V_{CD}	V		< 0.2		
Reaction time @ 10 % of I_{PRN}	t_{ra}	μs		7		$R_L > 500\text{ k}\Omega$, $di/dt > 5\text{ A}/\mu s$
Step response time to 90 % of I_{PN}	t_r	μs		50		$R_L > 500\text{ k}\Omega$, $di/dt > 5\text{ A}/\mu s$
Frequency bandwidth (-3dB)	BW	KHz		15		$R_L > 500\text{ k}\Omega$
Noise(1 Hz ~ 10 kHz)	V_{no}	mV rms		10		$R_L > 500\text{ k}\Omega$
Accuracy@ I_{PN} @TA = 25°C	$X_{25^\circ c}$	% of I_{PN}		± 1.9		
Accuracy@ I_{PN} @TA = 105°C	$X_{105^\circ c}$	% of I_{PN}		± 3.2		

4. Electrical data: SFG-0.6P/P2F

At $T_A = 25\text{ }^\circ\text{C}$, $V_C = 5\text{ V}$.

Parameters	Symbol	Unit	Min	Typ	Max	Remark
Primary nominal residual rms current	I_{PN}	A		0.6		
Primary residual current, measuring range	I_{PM}	A	-0.85		0.85	
Supply voltage	V_C	V	4.75	5	5.25	
Current consumption	I_C	mA		17.5	21.6	$I_P(\text{mA}) / N_a$ $N_a = 1000\text{ turns}$ - 40°C ... 105°C
Output voltage referred to V_{ref} (Test current)	V_{out}	V	0.4	0.75	1.1	
Reference voltage @ $I_P = 0$	V_{ref}	V	2.495	2.5	2.505	Internal reference
External reference voltage	V_{REF}	V	2.3		4	Internal reference of V_{ref} input = 499 Ω
Electrical offset current referred to primary	I_{OE}	mA	-24	4.2	24	
Temperature coefficient of VOE @ $I_P = 0$	TCV_{OE}	ppm/K			± 520	ppm/K of 2.5 V -40 ... 105 °C
Theoretical sensitivity	G_{th}	V/A		2.476		
Sensitivity error	ϵ_G	%	-0.7	0.5	0.7	$R_L > 500\text{ k}\Omega$
Temperature coefficient of G	TCG	ppm/K			± 100	- 40°C ... 105°C
Linearity error	ϵ_L	%		0.4	1.3	
Check current	I_{CK}	mA		100		10%
Output voltage(Check function)	V_{CK}	V		VOS+0.25		

Check enable voltage	V_{CE}	V	3.3		V_C	
Check disabled voltage	V_{CD}	V		< 0.2		
Reaction time @ 10 % of I_{PN}	t_{ra}	μs		5		$R_L > 500\ k\Omega$, $di/dt > 5\ A/\mu s$
Step response time to 90 % of I_{PN}	t_r	μs		40		$R_L > 500\ k\Omega$
Frequency bandwidth (-3dB)	BW	kHz		15		$R_L > 500\ k\Omega$
Noise(1 Hz ~ 10 kHz)	V_{no}	mV rms		10		
Accuracy@ I_{PN} @TA = 25°C	X_{25c}	% of I_{PN}		± 1.9		
Accuracy@ I_{PN} @TA = 105°C	X_{105c}	% of I_{PN}		± 3.2		

5. Electrical data: SFG-1.0P/P2F

At $T_A = 25\text{ }^\circ\text{C}$, $V_C = 5\text{ V}$.

Parameters	Symbol	Unit	Min	Typ	Max	Remark
Primary nominal residual rms current	I_{PN}	A		1		
Primary residual current, measuring range	I_{PM}	A	-1.7		1.7	
Supply voltage	V_C	V	4.75	5	5.25	
Current consumption	I_C	mA		17.5	21.6	$I_P(\text{mA}) / N_a$ $N_a = 1000\text{ turns}$ - 40°C ...105°C
Output voltage referred to V_{ref} (Test current)	V_{out}	V	0.2	0.35	0.5	
Reference voltage @ $I_P = 0$	V_{ref}	V	2.495	2.5	2.505	Internal reference
External reference voltage	V_{REF}	V	2.3		4	Internal reference of V_{ref} input = 499 Ω
Electrical offset current referred to primary	I_{OE}	mA	-24	7	24	
Temperature coefficient of VOE @ $I_P = 0$	TCV_{OE}	ppm/K		± 50	± 500	ppm/K of 2.5 V -40 ... 105 °C
Theoretical sensitivity	G_{th}	V/A		1.17		
Sensitivity error	ϵ_G	%	-1.6	0.5	1.6	$R_L > 500\text{ k}\Omega$
Temperature coefficient of G	TCG	ppm/K			± 400	- 40°C ...105°C
Linearity error	ϵ_L	%		0.5	1	
Check current	I_{CK}	mA		170		10%
Output voltage(Check function)	V_{CK}	V		VOS+0.2		

Check enable voltage	V_{CE}	V	3.3		V_C	
Check disabled voltage	V_{CD}	V		< 0.2		
Reaction time @ 10 % of I_{PRN}	t_{ra}	μs		7		$R_L > 500\text{ k}\Omega$, $di/dt > 5\text{ A}/\mu s$
Step response time to 90 % of I_{PN}	t_r	μs		50		$R_L > 500\text{ k}\Omega$, $di/dt > 5\text{ A}/\mu s$
Frequency bandwidth (-3dB)	BW	kHz		15		$R_L > 500\text{ k}\Omega$
Noise(1 Hz ~ 10 kHz)	V_{no}	mV rms		10		$R_L > 500\text{ k}\Omega$
Accuracy@ I_{PN} @TA = 25°C	$X_{25^\circ c}$	% of I_{PN}		± 1.9		
Accuracy@ I_{PN} @TA = 105°C	$X_{105^\circ c}$	% of I_{PN}		± 3.2		

6. Electrical data: SFG-1.5P/P2F

At $T_A = 25\text{ }^\circ\text{C}$, $V_C = 5\text{ V}$.

Parameters	Symbol	Unit	Min	Typ	Max	Remark
Primary nominal residual rms current	I_{PN}	A		1.5		
Primary residual current, measuring range	I_{PM}	A	-2		2	
Supply voltage	V_C	V	4.75	5	5.5	
Current consumption	I_C	mA		17.5	21.6	$I_P(\text{mA}) / N_a$ $N_a = 1000\text{ turns}$ - 40°C ... 105°C
Output voltage referred to V_{ref} (Test current)	V_{out}	V	0.12		0.5	
Reference voltage @ $I_P = 0$	V_{ref}	V	2.495	2.5	2.505	Internal reference
External reference voltage	V_{REF}	V	2.3		4	Internal reference of V_{ref} input = 499 Ω
Electrical offset current referred to primary	I_{OE}	mA	-30	4.2	30	
Temperature coefficient of VOE @ $I_P = 0$	TCV_{OE}	ppm/K			± 570	ppm/K of 2.5 V -40 ... 105 °C
Theoretical sensitivity	G_{th}	V/A		0.8		
Sensitivity error	ϵ_G	%	-1.6	0.5	1.6	$R_L > 500\text{ k}\Omega$
Temperature coefficient of G	TCG	ppm/K			± 400	- 40°C ... 105°C
Linearity error	ϵ_L	%		0.5	1	
Check current	I_{CK}	mA		100		10%
Output voltage(Check function)	V_{CK}	V		VOS+0.08		

Check enable voltage	V_{CE}	V	3.3		V_C	
Check disabled voltage	V_{CD}	V		< 0.2		
Reaction time @ 10 % of I_{PRN}	t_{ra}	μs		5		$R_L > 500 \text{ k}\Omega$, $di/dt > 5 \text{ A}/\mu s$
Step response time to 90 % of I_{PN}	t_r	μs		50		$R_L > 500 \text{ k}\Omega$, $di/dt > 5 \text{ A}/\mu s$
Frequency bandwidth (-3dB)	BW	kHz		15		$R_L > 500 \text{ k}\Omega$
Noise(1 Hz ~ 10 kHz)	V_{no}	mV rms		10		$R_L > 500 \text{ k}\Omega$
Accuracy@ I_{PN} @TA = 25°C	$X_{25^\circ C}$	% of I_{PN}		± 1.9		
Accuracy@ I_{PN} @TA = 105°C	$X_{105^\circ C}$	% of I_{PN}		± 3.2		

7. Electrical data: SFG-2.0P/P2F

At $T_A = 25^\circ C$, $V_C = 5 \text{ V}$.

Parameters	Symbol	Unit	Min	Typ	Max	Remark
Primary nominal residual rms current	I_{PN}	A		2		
Primary residual current, measuring range	I_{PM}	A	-3		3	
Supply voltage	V_C	V	4.75	5	5.5	
Current consumption	I_C	mA		17.5	21.6	$I_P(\text{mA}) / N_a$ $N_a = 1000 \text{ turns}$ - 40°C ... 105°C
Reference voltage @ $I_P = 0$	V_{ref}	V	2.495	2.5	2.505	Internal reference
External reference voltage	V_{REF}	V	2.3		4	Internal reference of V_{ref} input = 499 Ω
Electrical offset current referred to primary	I_{OE}	mA	-24	7	24	

Temperature coefficient of VOE @ $I_P = 0$	TCV _{OE}	ppm/K			570	ppm/K of 2.5 V -40 ... 105 °C
Theoretical sensitivity	G _{th}	V/A		0.66		
Sensitivity error	ϵ_G	%	-1.6	0.5	1.6	R _L > 500 k Ω
Temperature coefficient of G	TCG	ppm/K		± 400		- 40°C ... 105°C
Linearity error	ϵ_L	%		0.5	1	
Check current	I _{CK}	mA		100		10%
Output voltage(Check function)	V _{CK}	V		VOS+0.066		
Check enable voltage	V _{CE}	V	3.3		V _C	
Check disabled voltage	V _{CD}	V		< 0.2		
Reaction time @ 10 % of I _{PN}	t _{ra}	μ s		5		R _L > 500 k Ω , di/dt > 5 A/ μ s
Step response time to 90 % of I _{PN}	t _r	μ s		40		R _L > 500 k Ω
Frequency bandwidth (-3dB)	BW	kHz		15		R _L > 500 k Ω
Noise(1 Hz ~ 10 kHz)	V _{no}	mV rms		10		
Accuracy@ I _{PN} @TA = 25°C	X _{25°C}	% of I _{PN}		± 1.9		
Accuracy@ I _{PN} @TA = 105°C	X _{105°C}	% of I _{PN}		± 3.2		

8. Electrical data: SFG-3.0P/P2F

At $T_A = 25\text{ }^\circ\text{C}$, $V_C = 5\text{ V}$.

Parameters	Symbol	Unit	Min	Typ	Max	Remark
Primary nominal residual rms current	I_{PN}	A		3		
Primary residual current, measuring range	I_{PM}	A	-5		5	
Supply voltage	V_C	V	4.75	5	5.5	
Current consumption	I_C	mA		17.5	21.6	$I_P(\text{mA}) / N_a$ $N_a = 1000\text{ turns}$ - 40°C ... 105°C
Reference voltage @ $I_P = 0$	V_{ref}	V	2.495	2.5	2.505	Internal reference
External reference voltage	V_{REF}	V	2.3		4	Internal reference of V_{ref} input = 499 Ω
Electrical offset current referred to primary	I_{OE}	mA	-24	7	24	
Temperature coefficient of VOE @ $I_P = 0$	TCV_{OE}	ppm/K			570	ppm/K of 2.5 V -40 ... 105 °C
Theoretical sensitivity	G_{th}	V/A		0.4		
Sensitivity error	ϵ_G	%	-1.6	0.5	1.6	$R_L > 500\text{ k}\Omega$
Temperature coefficient of G	TCG	ppm/K		± 400		- 40°C ... 105°C
Linearity error	ϵ_L	%		0.5	1	
Check current	I_{CK}	mA		100		10%
Output voltage(Check function)	V_{CK}	V		VOS+0.04		
Check enable voltage	V_{CE}	V	3.3		V_C	
Check disabled voltage	V_{CD}	V		< 0.2		

Reaction time @ 10 % of I_{PN}	t_{ra}	μs		5		$R_L > 500\ k\Omega$, $di/dt > 5\ A/\mu s$
Step response time to 90 % of I_{PN}	t_r	μs		40		$R_L > 500\ k\Omega$
Frequency bandwidth (-3dB)	BW	kHz		15		$R_L > 500\ k\Omega$
Noise(1 Hz ~ 10 kHz)	V_{no}	mV rms		10		
Accuracy@ I_{PN} @TA = 25°C	$X_{25^\circ c}$	% of I_{PN}		± 1.9		
Accuracy@ I_{PN} @TA = 105°C	$X_{105^\circ c}$	% of I_{PN}		± 3.2		

9. PCB footprint

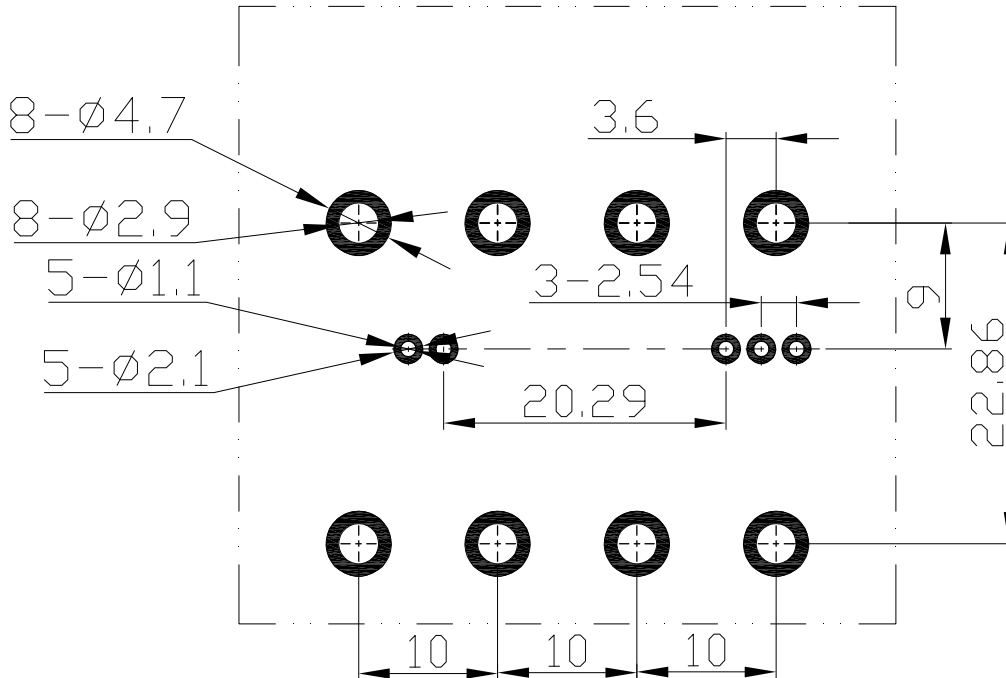

Assembly on PCB

- Maximum PCB thickness 2.4 mm
- Wave-soldering: 260°C @ 10 s
- Recommended PCB hole diameter 1.1 mm for secondary pin

2.9 mm for secondary pin

10. Dimensions

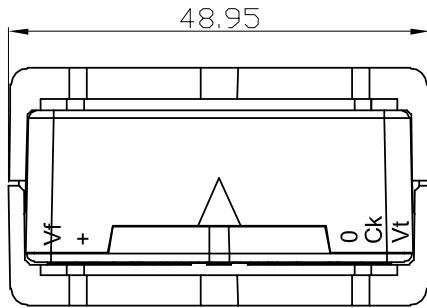

	D _{C1}	D _{Cp}
B-C	7.5	8.4
A-C	6.7	7.7
C-D	—	13

D is secondary inside the transducer

On the customer's PCBA		
	D _{C1}	D _{Cp}
B-C	5.6	5.6
A-C	5.3	5.3

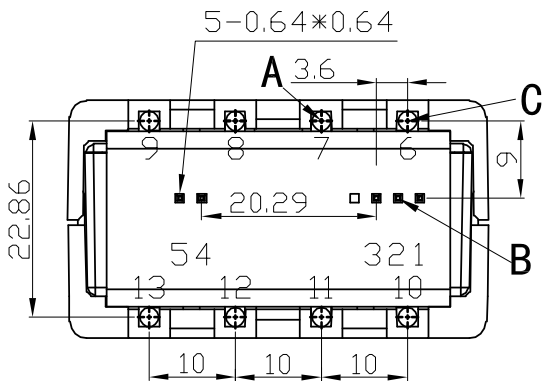
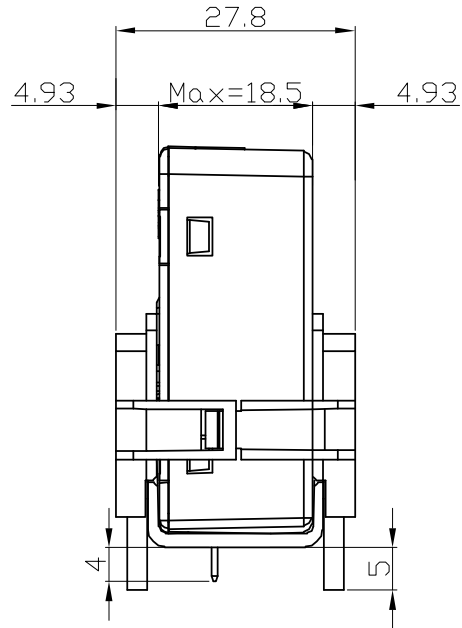
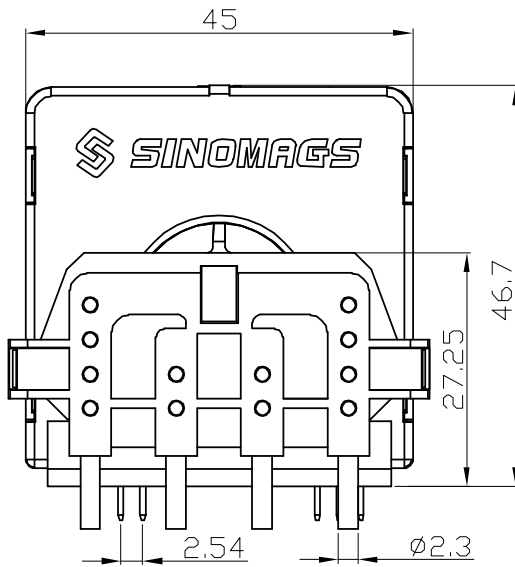

Terminals:

1	Vout	8	Ip+
2	CHK	9	Ip+
3	GND	10	Ip-
4	Vcc	11	Ip-
5	Vref	12	Ip-
6	Ip+	13	Ip-
7	Ip+		

Material : Fit UL94V-0 & RoHS requirements ;

General tolerance : ±0.5

Unit :mm

