

CURRENT SENSOR

PRODUCT SERIES: SFG-X.XP/P4
PRODUCT PART NUMBER: SFG-3.0P/P4,
SFG-5.0P/P4

Version: Ver 1.0

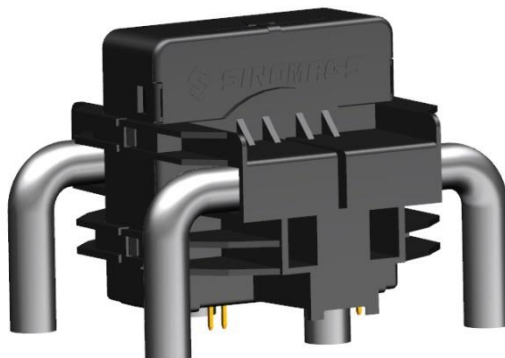

Technology Co., Ltd

site: www.sinomags.com

CONTENT

1.	Description.....	2
2.	Absolute parameter: SFG-X.XP/P4	3
3.	Electrical data: SFG-3.0P/P4.....	4
4.	Electrical data: SFG-5.0P/P4.....	5
5.	SFG- P/P4 PCB footprint.....	7
6.	SFG- P/P4 Dimensions.....	8

1. Description

Features

- Closed loop (compensated) current transducer
- Voltage output
- Insulation voltage for 5 kVAC
- Single supply voltage

Advantages

- High accuracy
- High overload capability
- High insulation capability
- High separation ability
- Low temperature drift
- Degauss and test functions

Applications

- Residual current measurement
- Leakage current measurement in PV inverters
- First human contact protection of PV arrays
- Failure detection in power sources
- Leakage current detection in stacked DC sources
- Communication power.

2. Absolute parameter: SFG-X.XP/P4

Absolute maximum ratings

Parameter	Symbol	Unit	Value
Maximum Supply voltage	$V_{C\ max}$	V	7
Maximum Primary conductor temperature	$T_{B\ max}$	°C	110
Maximum overload capability (100 μ s, 500 A/ μ s)	$\hat{I}_{P\ max}$	A	3300
Maximum Voltage between test winding and secondary pins	$V_{d\ max}$	V	35
Maximum Current of test winding	$I_{T\ max}$	mA	300

Ratings

Parameter	Symbol	Unit	Value
Primary involved potential		V AC/DC	1000
Primary current @ $T_{Amax}=105^{\circ}C$	I_P	A	220
Primary current @ $T_{Amax}=85^{\circ}C$	I_P	A	250
Secondary supply voltage	U_C	V DC	5
Output voltage	V_{out}	V	0 to 5

Isolation parameters

Parameter	Symbol	Unit	Value	Remark
RMS voltage for AC	V_d	kV	4	test 50 Hz/1 min
Impulse withstand voltage	V_w	kV	10.1	1.2/50 μ s
Clearance distance (pri. –pri.)	d_{Cl}	mm	11	Shortest distance through air
Creepage distance (pri. – pri.)	d_{Cp}	mm	16	Shortest path along device body
Clearance distance (pri. –sec.)	d_{Cl}	mm	12.1	When mounted on PCB with recommended layout
Creepage distance (pri. –sec.)	d_{Cp}	mm	12.1	When mounted on PCB with recommended layout
Comparative tracking index	CTI	V	600	

Application example		V	600 CAT III, PD2	Reinforced insulation, non uniform field
Application example		V	1500 CAT III, PD2	Basic insulation, non uniform field

Environmental and mechanical characteristics

Parameter	Symbol	Unit	Min	Typ	Max	Comment
Ambient operating temperature	T_A	°C	-40		85	
Ambient storage temperature	T_S	°C	-40		105	
Mass	m	g		300		
standard	EN 50178, IEC 61010, UL 508					

3. Electrical data: SFG-3.0P/P4

At $T_A = 25\text{ °C}$, $V_C = 5\text{ V}$.

Parameters	Symbol	Unit	Min	Typ	Max	Remark
Primary nominal residual rms current	I_{PN}	A		3		
Primary residual current, measuring range	I_{PM}	A	-5		5	
Supply voltage	V_C	V	4.75	5	5.5	
Current consumption	I_C	mA		17.5	21.6	$I_P(\text{mA}) / N_a$ $N_a = 1000\text{ turns}$ - 40°C ... 105°C
Reference voltage @ $I_P = 0$	V_{ref}	V	2.495	2.5	2.505	Internal reference
External reference voltage	V_{REF}	V	2.3		4	Internal reference of V_{ref} input = 499Ω
Electrical offset current referred to primary	I_{OE}	mA	-24	7	24	
Temperature coefficient of VOE @ $I_P = 0$	TCV_{OE}	ppm/K			570	ppm/K of 2.5 V -40 ... 105 °C

Theoretical sensitivity	Gth	V/A		0.4		
Sensitivity error	ϵ_G	%	-1.6	0.5	1.6	$R_L > 500\text{ k}\Omega$
Temperature coefficient of G	TCG	ppm/K		± 400		-40°C ... 105°C
Linearity error	ϵ_L	%		0.5	1	
Number of turns (test winding)	N_T			20		$R_L > 500\text{ k}\Omega$, $di/dt > 5\text{ A}/\mu\text{s}$
Reaction time @ 10 % of I_{PN}	t_{ra}	μs		5		$R_L > 500\text{ k}\Omega$, $di/dt > 5\text{ A}/\mu\text{s}$
Step response time to 90 % of I_{PN}	t_r	μs		40		$R_L > 500\text{ k}\Omega$
Frequency bandwidth (-3dB)	BW	kHz		15		$R_L > 500\text{ k}\Omega$
Noise(1 Hz ~ 10 kHz)	V_{no}	mV rms		10		
Accuracy@ I_{PN} @TA = 25°C	$X_{25^\circ\text{C}}$	% of I_{PN}		± 1.9		
Accuracy@ I_{PN} @TA = 105°C	$X_{105^\circ\text{C}}$	% of I_{PN}		± 3.2		

4. Electrical data: SFG-5.0P/P4

At $T_A = 25^\circ\text{C}$, $V_C = 5\text{ V}$.

Parameters	Symbol	Unit	Min	Typ	Max	Remark
Primary nominal residual rms current	I_{PN}	A		5		
Primary residual current, measuring range	I_{PM}	A	-8		8	
Supply voltage	V_C	V	4.75	5	5.5	

Current consumption	I_C	mA		17.5	21.6	$I_P(\text{mA}) / N_a$ $N_a = 1000$ turns - 40°C ... 105°C
Reference voltage @ $I_P = 0$	V_{ref}	V	2.495	2.5	2.505	Internal reference
External reference voltage	V_{REF}	V	2.3		4	Internal reference of V_{ref} input = 499 Ω
Electrical offset current referred to primary	I_{OE}	mA	-35	12	35	
Temperature coefficient of VOE @ $I_P = 0$	TCV_{OE}	ppm/K			570	ppm/K of 2.5 V -40 ... 105 °C
Theoretical sensitivity	G_{th}	V/A		0.2		
Sensitivity error	ϵ_G	%	-1.6	0.5	1.6	$R_L > 500$ k Ω
Temperature coefficient of G	TCG	ppm/K		± 400		- 40°C ... 105°C
Linearity error	ϵ_L	%		0.5	1	
Number of turns (test winding)	N_T			20		$R_L > 500$ k Ω , $di/dt > 5$ A/ μs
Reaction time @ 10 % of I_{PRN}	t_{ra}	μs		5		$R_L > 500$ k Ω , $di/dt > 5$ A/ μs
Step response time to 90 % of I_{PN}	t_r	μs		40		$R_L > 500$ k Ω
Frequency bandwidth (-3dB)	BW	kHz		15		$R_L > 500$ k Ω
Noise(1 Hz ~ 10 kHz)	V_{no}	mV rms		10		
Accuracy@ I_{PN} @TA = 25°C	$X_{25^\circ\text{C}}$	% of I_{PN}		± 1.9		
Accuracy@ I_{PN} @TA = 105°C	$X_{105^\circ\text{C}}$	% of I_{PN}		± 3.2		

6. SFG- P/P4 Dimensions

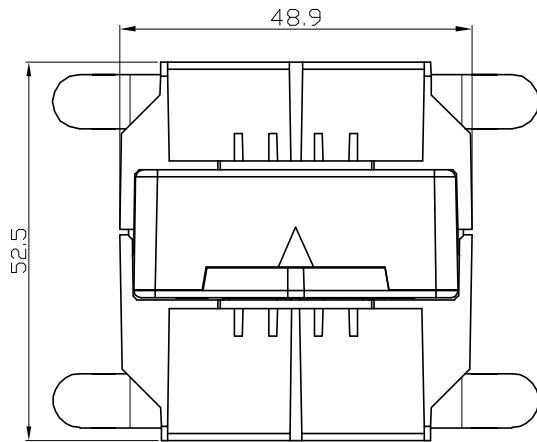

Terminals :

1	2	3
Vcc	GND	Vref
4	5	6
Vout	Test Out	Test In
7	8	9
Ip+	Ip+	Ip+
10	11	12
Ip-	Ip-	Ip-

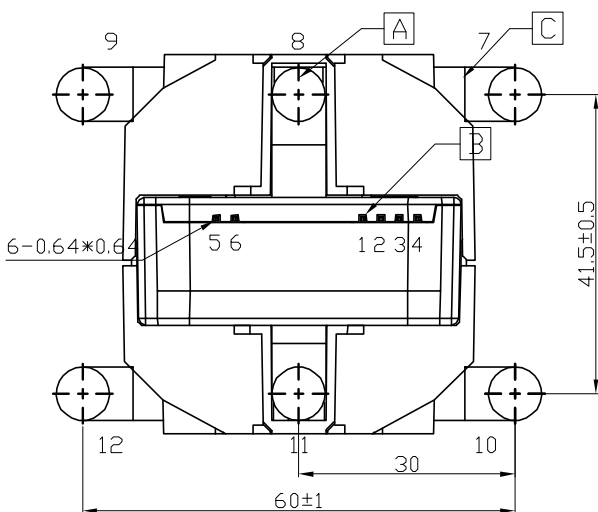
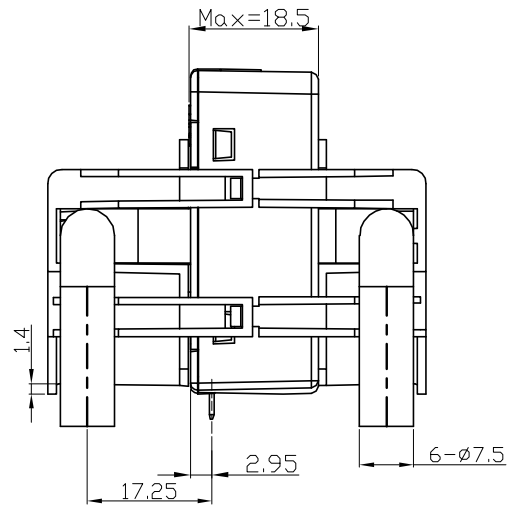
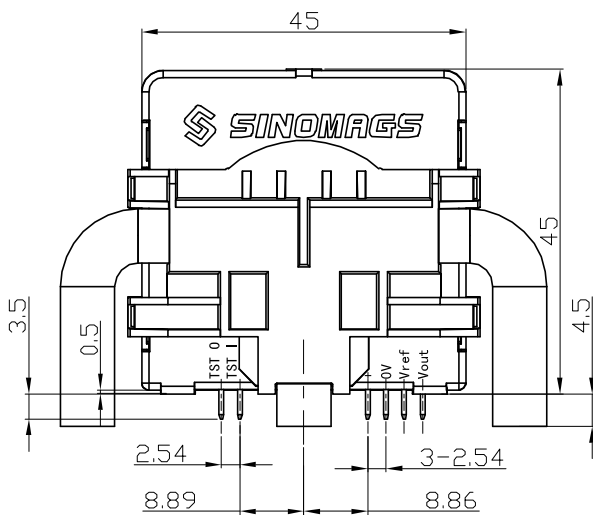

	d_{CI}	d_{CP}
A-B	15.3mm	---
A-C	11mm	16mm
C-D	16.0mm	16.0mm

D is secondary inside the transducer

On the customer's PCBA		
	d_{CI}	d_{CP}
A-B	12.1mm	12.1mm
A-C	11mm	17.5mm

Material : Fit UL94V-0 & RoHS requirements ;

General tolerance : ± 0.5

Unit : mm

