



CURRENT SENSOR

PRODUCT SERIES: SHK-VBS/D

PRODUCT PART NUMBER: SHK-VBS/D-A
SHK-VBS/D-B
SHK-VBS/D-C
SHK-VBS/D-D
SHK-VBS/D-E
SHK-VBS/D-H

VERSION: Ver2.1



Sinomags Technology Co., Ltd.

Web site: www.sinomags.com

CONTENTS

1. Description	2
2. Electrical data SHK-VBS/D-A	3
3. Electrical data SHK-VBS/D-B	5
4. Electrical data SHK-VBS/D-C	7
5. Electrical data SHK-VBS/D-D	9
6. Electrical data SHK-VBS/D-E	11
7. Electrical data SHK-VBS/D-H	13
8. Electrical data SHK-VBS/D-J	15
9. Frequency band width.....	17
10. SHK-VBS/D Dimensions & Pins & Footprint	18
11. Typical application	19

1. Description

The SHK-VBS/D series current sensor is based on TMR (tunnel magnetoresistance) technology and open-loop design. It is suitable for DC, AC pulsed and any kind of irregular current measurement under the isolated conditions.

Typical applications

- AC Variable speed drives
- Electric welder power supply
- Inverter
- Switched model power supplies (SMPS)

General parameter

Parameter	Symbol	Unit	Value
Working temperature	T_A	°C	-40 ~ 125
Storage temperature	T_stg	°C	-40 ~ 125
Mass	m	g	80

Absolute maximum rating

Parameter	Symbol	Unit	Value
Supply voltage	V _{cc}	V	6
ESD rating (HBM)	U_ESD	kV	8

Remark: the unrecoverable damage may occur when the product works on the conditions over the absolute maximum ratings. Long-time working on the absolute maximum ratings may cause the degradation on performance and reliability.

Isolation parameter

Parameter	Symbol	Unit	Value	Comment
RMS voltage for AC test 50Hz/1 min	U _d	kV	2.5	
Impulse withstand voltage 1.2/50μs	Ū _w	kV	6	
Insulation resistance	R _{is}	MΩ	500	
Clearance distance (pri. -sec)	d _{Cl}	mm	3.1	Determined by customer's layout
Creepage distance (pri. -sec)	d _{Cp}	mm	3.1	

Measuring current table

Product	Channel	Optimized Range I _{pn} (A)	Sensitivity, (mV/A)	T(°C)
SHK-VBS/D-A	CH1	±75 A	26.67	-40 ~ 125
	CH2	±1000 A	2	-40 ~ 125
SHK-VBS/D-B	CH1	±75 A	26.7	-40 ~ 125
	CH2	±750 A	2.7	-40 ~ 125
SHK-VBS/D-C	CH1	±75 A	26.7	-40 ~ 125
	CH2	±500 A	4	-40 ~ 125
SHK-VBS/D-D	CH1	±30 A	66.7	-40 ~ 125
	CH2	±350 A	5.7	-40 ~ 125
SHK-VBS/D-E	CH1	±40 A	50	-40 ~ 125
	CH2	±400 A	5	-40 ~ 125
SHK-VBS/D-H	CH1	±30 A	66.7	-40 ~ 125
	CH2	±500 A	4	-40 ~ 125
SHK-VBS/D-J	CH1	±60 A	33.333	-40 ~ 125
	CH2	±600 A	3.333	-40 ~ 125

2. Electrical data SHK-VBS/D-A

Condition: Vcc = 5.0 V, T_A = 25°C, unless specified.

Parameters	Symbol	Unit	Min.	Typ.	Max.	Remark
Primary current	I _{pn}	A	-75		75	CH1
			-1000		1000	CH2
Supply voltage	V _{cc}	V	4.75	5	5.25	
Consumption current	I _{cc}	mA	21	28	35	
Full-scale output	V _{FS}	V		±2		(V _{out} @ ±I _{pn}) – V _{off}
Output resistance	R _{out}	kΩ		5		@V _{out}
Offset voltage	V _{off}	V	2.496	2.5	2.504	V _{cc} =5V
Theoretical gain	G _{th}	mV/A		26.67		CH1
				2		CH2
Non-linearity	Non-L	%I _{pn}	-1	0.5	1	±I _{pn}
Step response time	t _{res}	μs		18	20	@90% of I _{PN}
-3dB band width	BW	kHz		10		Back-end non-RC circuit
Noise	V _{noise}	mVpp				
DC ~ 10 kHz				15		
DC ~ 100 kHz				20		

Note:

- Accuracy @ RT,X = ((V_{out} @ I_n @ 25°C) – (G_{fit} * I_n + V_{off} @ 25°C)) / V_{FS}, Here I_n is the current test current. G_{fit} is the normal temperature fitting gain.
- Accuracy, X_TRange = ((V_{out} @ I_n @ T_x) – (G_{fit}@25°C * I_n + V_{off} @ 25°C)) / V_{FS}, The fitting gain of the product at G_{fit}@25 °C is 25 °C.

Accuracy table: SHK-VBS/D-A CH1

Parameter	Symbol	Unit	Temperature					
			-40°C	-20°C	0°C	25°C	65°C	125°C
Accuracy@0A	X	A	0.35	0.29	0.23	0.15	0.23	0.35
Accuracy@±25A			1.20	1.05	0.89	0.7	0.90	1.20
Accuracy@±75A			2.50	2.13	1.76	1.3	1.78	2.50

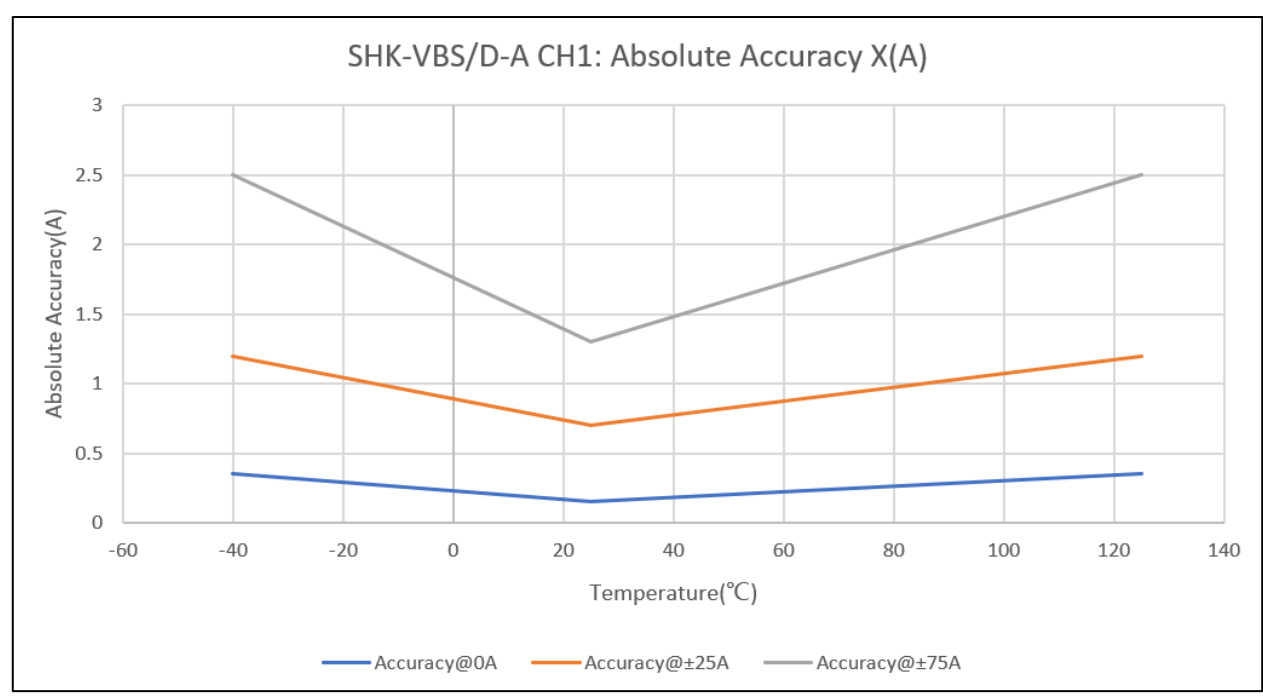

Accuracy table: SHK-VBS/D-A CH2

Parameter	Symbol	Unit	Temperature					
			-40°C	-20°C	0°C	25°C	65°C	125°C
Accuracy@0A	X	A	4.5	4	3.6	3	3.6	4.5
Accuracy@±500A			22.0	18.0	14.0	9.0	14.2	22.0
Accuracy@±900A			38.0	30.9	23.9	15.0	24.2	38.0
Accuracy@±1000A			44.0	36.6	29.2	20.0	29.6	44.0

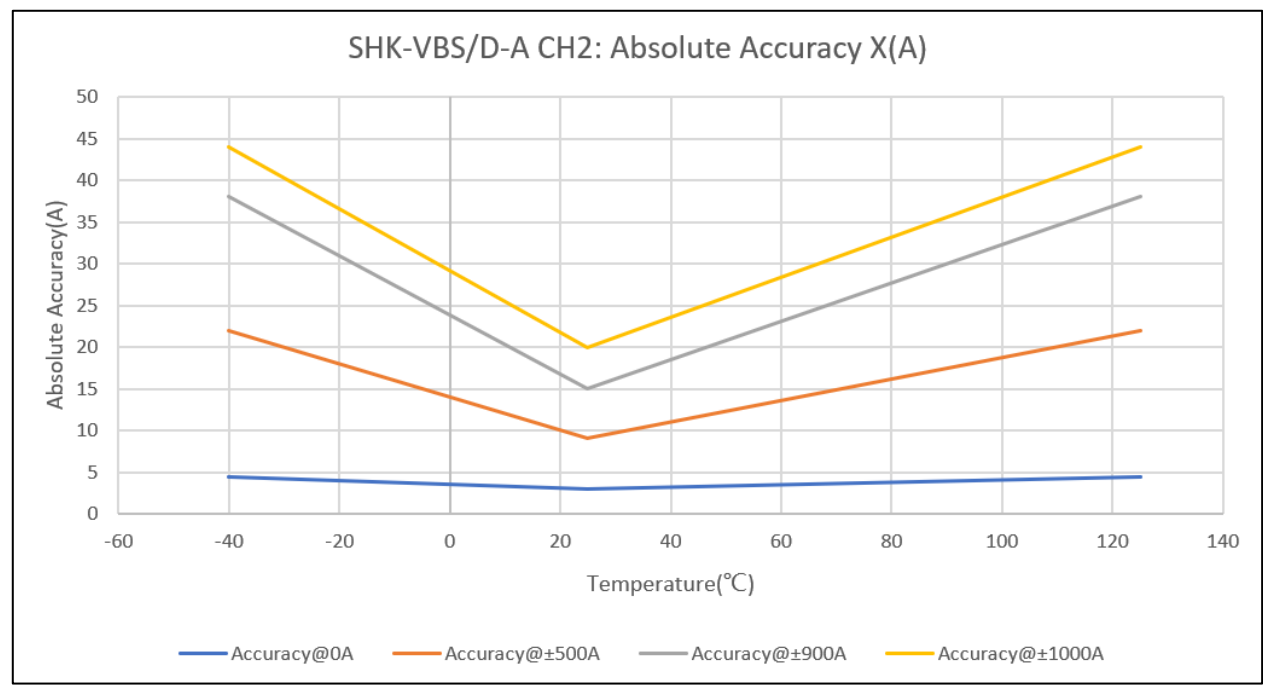

3. Electrical data SHK-VBS/D-B

Condition: Vcc = 5.0 V, T_A = 25°C, unless specified.

Parameters	Symbol	Unit	Min.	Typ.	Max.	Remark
Primary current	I _{pn}	A	-75		75	CH1
			-750		750	CH2
Supply voltage	V _{cc}	V	4.75	5	5.25	
Consumption current	I _{cc}	mA	21	28	35	
Full-scale output	V _{FS}	V		±2		(V _{out} @ ±I _{pn}) – V _{off}
Output resistance	R _{out}	kΩ		5		@V _{out}
Offset voltage	V _{off}	V	2.496	2.5	2.504	V _{cc} =5V
Theoretical gain	G _{th}	mV/A		26.7		CH1
				2.7		CH2
Non-linearity	Non-L	%I _{pn}	-1	0.5	1	±I _{pn}
Step response time	t _{res}	μs		18	20	@90% of I _{PN}
-3dB band width	BW	kHz		10		Back-end non-RC circuit
Noise	V _{noise}	mVpp				
DC ~ 10 kHz				15		
DC ~ 100 kHz				20		

Note:

- Accuracy @ RT, X = ((V_{out} @ I_n @ 25°C) – (G_{fit} * I_n + V_{off} @ 25°C)) / V_{FS}, Here I_n is the current test current. G_{fit} is the normal temperature fitting gain.
- Accuracy, X_TRange = ((V_{out} @ I_n @ T_x) – (G_{fit}@25°C * I_n + V_{off} @ 25°C)) / V_{FS}, The fitting gain of the product at G_{fit}@25 °C is 25 °C.

Accuracy table: SHK-VBS/D-B CH1

Parameter	Symbol	Unit	Temperature					
			-40°C	-20°C	0°C	25°C	65°C	125°C
Accuracy@0A	X	A	0.35	0.29	0.23	0.15	0.23	0.35
Accuracy@±37A			1.50	1.25	1.01	0.7	1.02	1.50
Accuracy@±75A			2.50	2.13	1.76	1.3	1.78	2.50

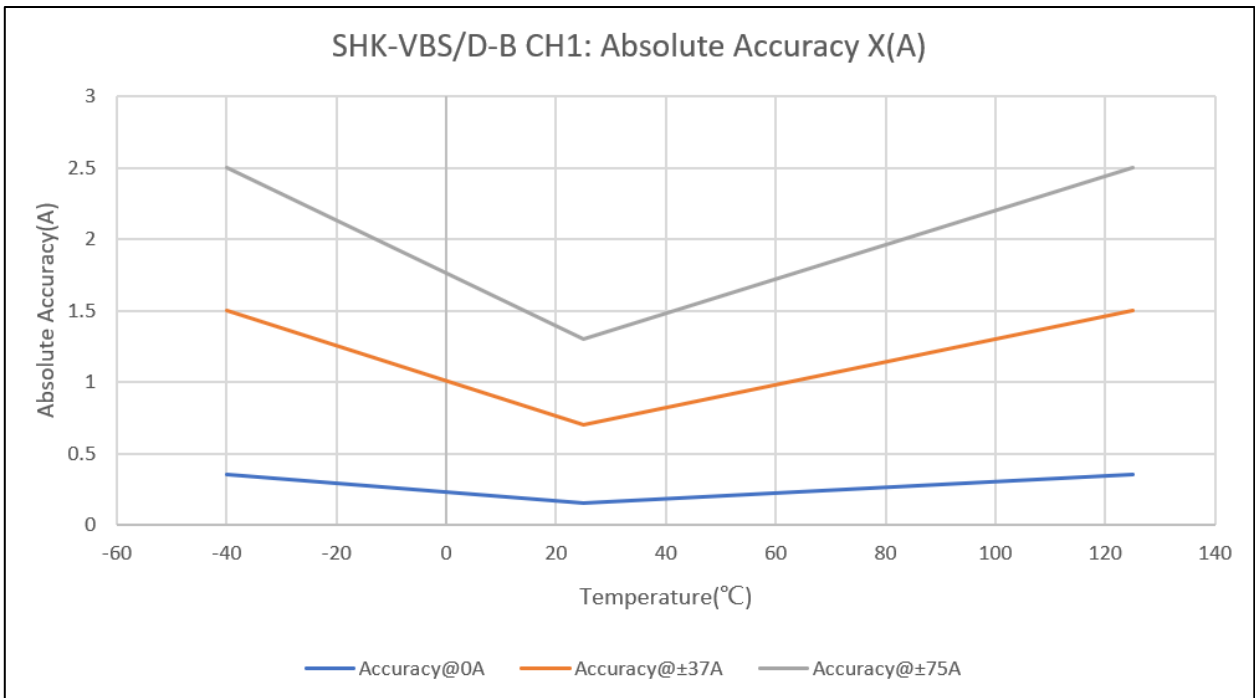

Accuracy table: SHK-VBS/D-B CH2

Parameter	Symbol	Unit	Temperature					
			-40°C	-20°C	0°C	25°C	65°C	125°C
Accuracy@0A	X	A	2.80	2.37	1.94	1.40	1.96	2.8
Accuracy@±375A			10.0	9.08	8.15	7.001	8.20	10.0
Accuracy@±750A			16.0	14.2	12.3	10.0	12.4	16.0

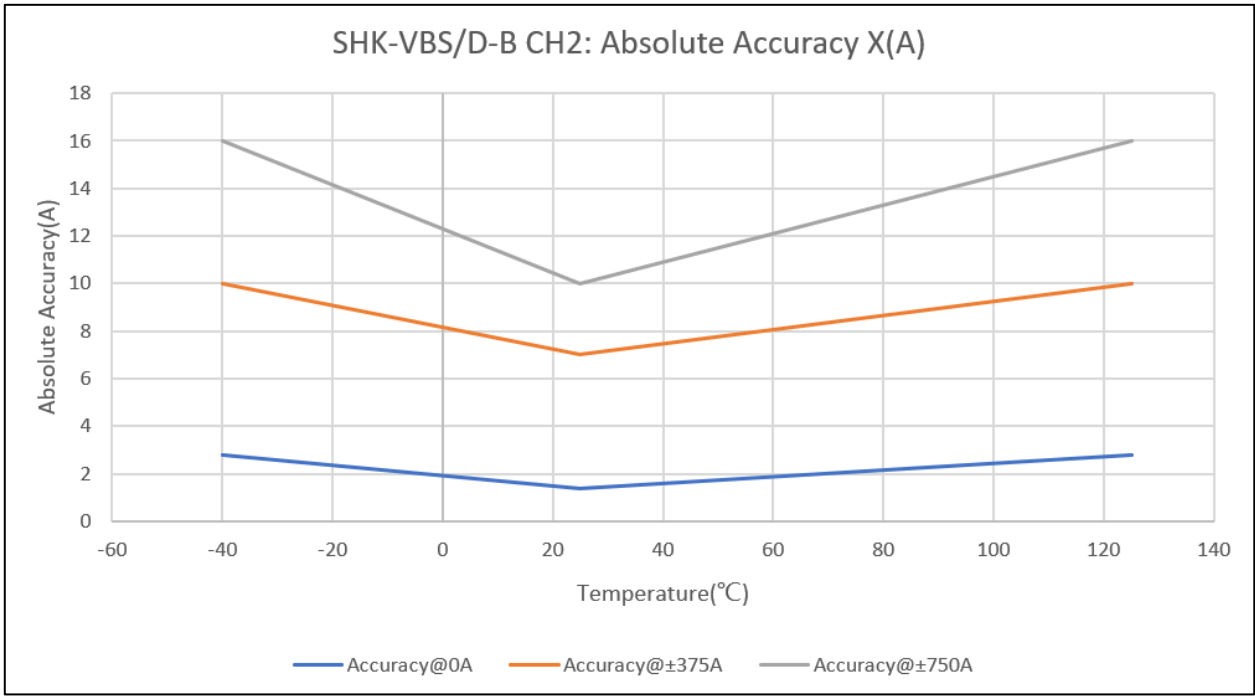

4. Electrical data SHK-VBS/D-C

Condition: Vcc = 5.0 V, T_A = 25°C, unless specified.

Parameters	Symbol	Unit	Min.	Typ.	Max.	Remark
Primary current	I _{pn}	A	-75		75	CH1
			-500		500	CH2
Supply voltage	V _{cc}	V	4.75	5	5.25	
Consumption current	I _{cc}	mA	21	28	35	
Full-scale output	V _{FS}	V		±2		(V _{out} @ ±I _{pn}) – V _{off}
Output resistance	R _{out}	kΩ		5		@V _{out}
Offset voltage	V _{off}	V	2.475	2.5	2.525	V _{cc} =5V
Theoretical gain	G _{th}	mV/A		26.7		CH1
				4		CH2
Non-linearity	Non-L	%I _{pn}	-1	0.5	1	±I _{pn}
Step response time	t _{res}	μs		18	20	@90% of I _{PN}
-3dB band width	BW	kHz		10		Back-end non-RC circuit
Noise	V _{noise}	mVpp				
DC ~ 10 kHz				15		
DC ~ 100 kHz				20		

Note:

5. Accuracy @ RT, X = ((V_{out} @ I_n @ 25°C) – (G_{fit} * I_n + V_{off} @ 25°C)) / V_{FS}, Here I_n is the current test current. G_{fit} is the normal temperature fitting gain.
6. Accuracy, X_TRange = ((V_{out} @ I_n @ T_x) – (G_{fit}@25°C * I_n + V_{off} @ 25°C)) / V_{FS}, The fitting gain of the product at G_{fit}@25 °C is 25 °C.

Accuracy table: SHK-VBS/D-C CH1

Parameter	Symbol	Unit	Temperature					
			-40°C	-20°C	0°C	25°C	65°C	125°C
Accuracy@0A	X	A	0.35	0.29	0.23	0.15	0.23	0.35
Accuracy@±37A			1.50	1.25	1.01	0.7	1.02	1.50
Accuracy@±75A			2.50	2.13	1.76	1.3	1.78	2.50

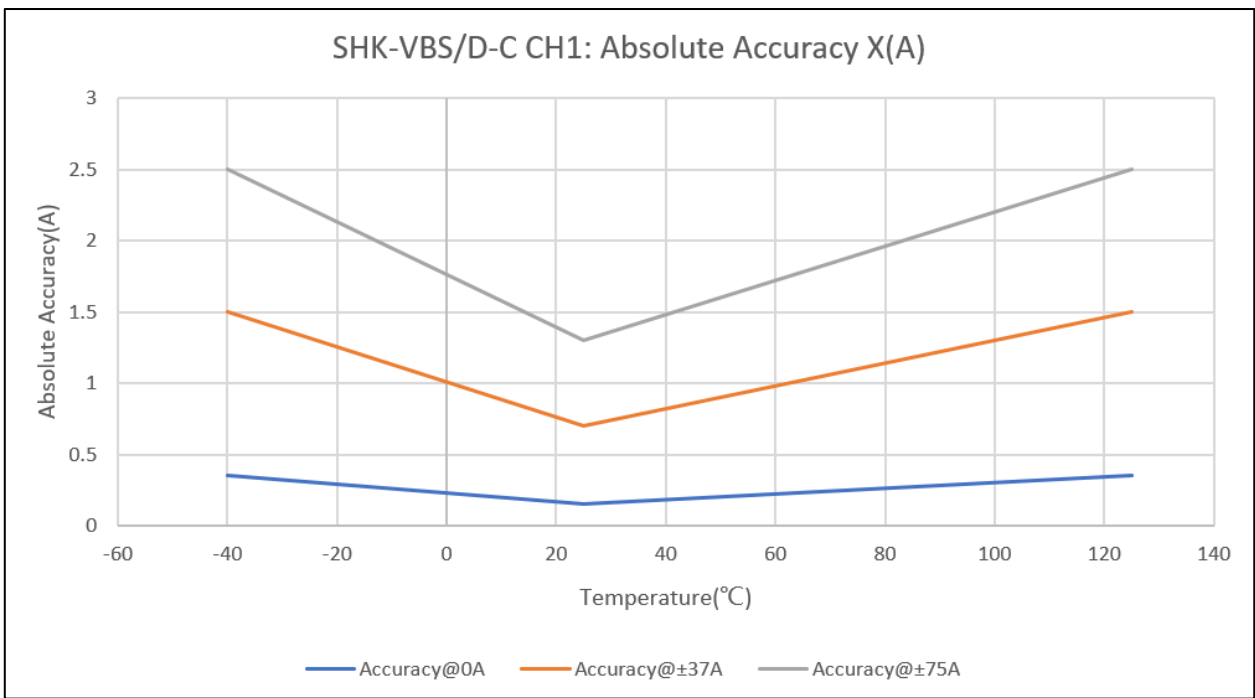

Accuracy table: SHK-VBS/D-C CH2

Parameter	Symbol	Unit	Temperature					
			-40°C	-20°C	0°C	25°C	65°C	125°C
Accuracy@0A	X	A	1.80	1.55	1.31	1.00	1.32	1.80
Accuracy@±250A			9.00	8.08	7.15	6.00	7.20	9.00
Accuracy@±500A			15.0	13.15	11.31	9.00	11.4	15.0

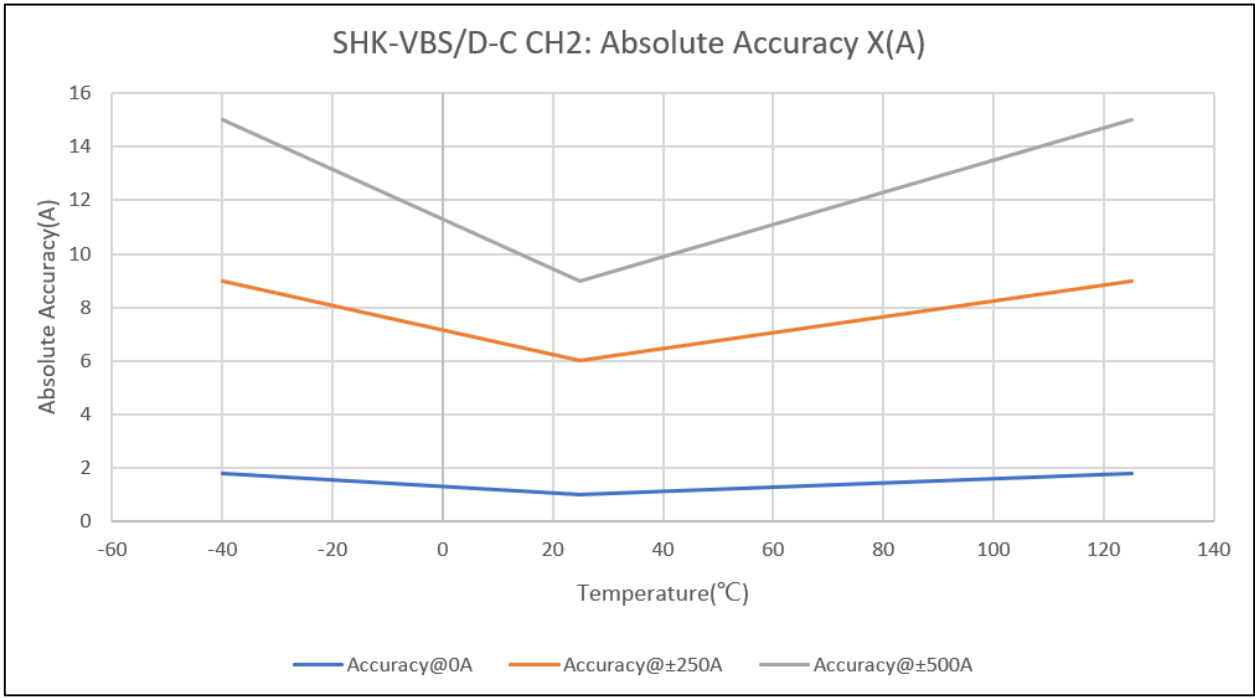

5. Electrical data SHK-VBS/D-D

Condition: Vcc = 5.0 V, T_A = 25°C, unless specified.

Parameters	Symbol	Unit	Min.	Typ.	Max.	Remark
Primary current	I _{pn}	A	-30		30	CH1
			-350		350	CH2
Supply voltage	V _{cc}	V	4.75	5	5.25	
Consumption current	I _{cc}	mA	21	28	35	
Full-scale output	V _{FS}	V		±2		(V _{out} @ ±I _{pn}) – V _{off}
Output resistance	R _{out}	kΩ		5		@V _{out}
Offset voltage	V _{off}	V	2.475	2.5	2.525	V _{cc} =5V
Theoretical gain	G _{th}	mV/A		66.7		CH1
				5.7		CH2
Non-linearity	Non-L	%I _{pn}	-1	0.5	1	±I _{pn}
Step response time	t _{res}	μs		18	20	@90% of I _{PN}
-3dB band width	BW	kHz		10		Back-end non-RC circuit
Noise	V _{noise}	mVpp				
DC ~ 10 kHz				15		
DC ~ 100 kHz				20		

Note:

7. Accuracy @ RT, X = ((V_{out} @ I_n @ 25°C) – (G_{fit} * I_n + V_{off} @ 25°C)) / V_{FS}, Here I_n is the current test current. G_{fit} is the normal temperature fitting gain.
8. Accuracy, X_TRange = ((V_{out} @ I_n @ T_x) – (G_{fit}@25°C * I_n + V_{off} @ 25°C)) / V_{FS}, The fitting gain of the product at G_{fit}@25 °C is 25 °C.

Accuracy table: SHK-VBS/D-D CH1

Parameter	Symbol	Unit	Temperature					
			-40°C	-20°C	0°C	25°C	65°C	125°C
Accuracy@0A	X	A	0.35	0.29	0.23	0.15	0.23	0.35
Accuracy@±20A			0.73	0.64	0.56	0.45	0.56	0.73
Accuracy@±30A			1.00	0.91	0.82	0.70	0.82	1.00

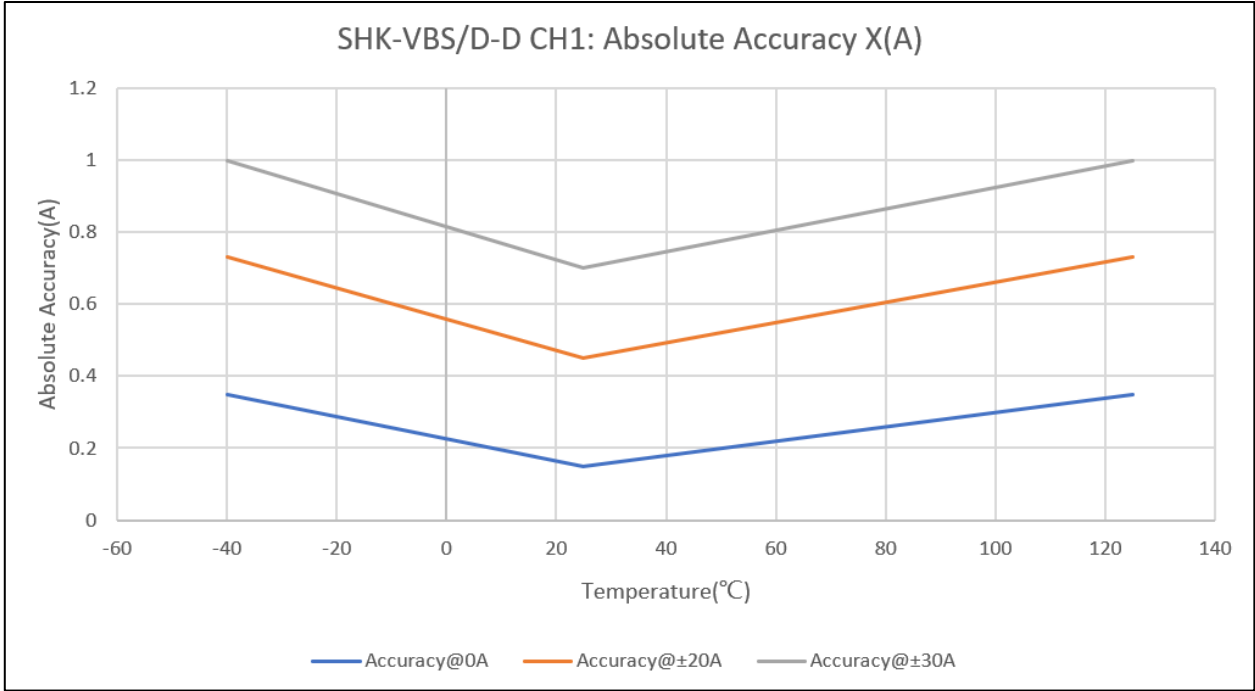

Accuracy table: SHK-VBS/D-D CH2

Parameter	Symbol	Unit	Temperature					
			-40°C	-20°C	0°C	25°C	65°C	125°C
Accuracy@0A	X	A	1.50	1.35	1.19	1.00	1.20	1.50
Accuracy@±175A			5.25	4.71	4.14	3.50	4.20	5.25
Accuracy@±350A			9.25	7.94	6.63	5.00	6.70	9.25

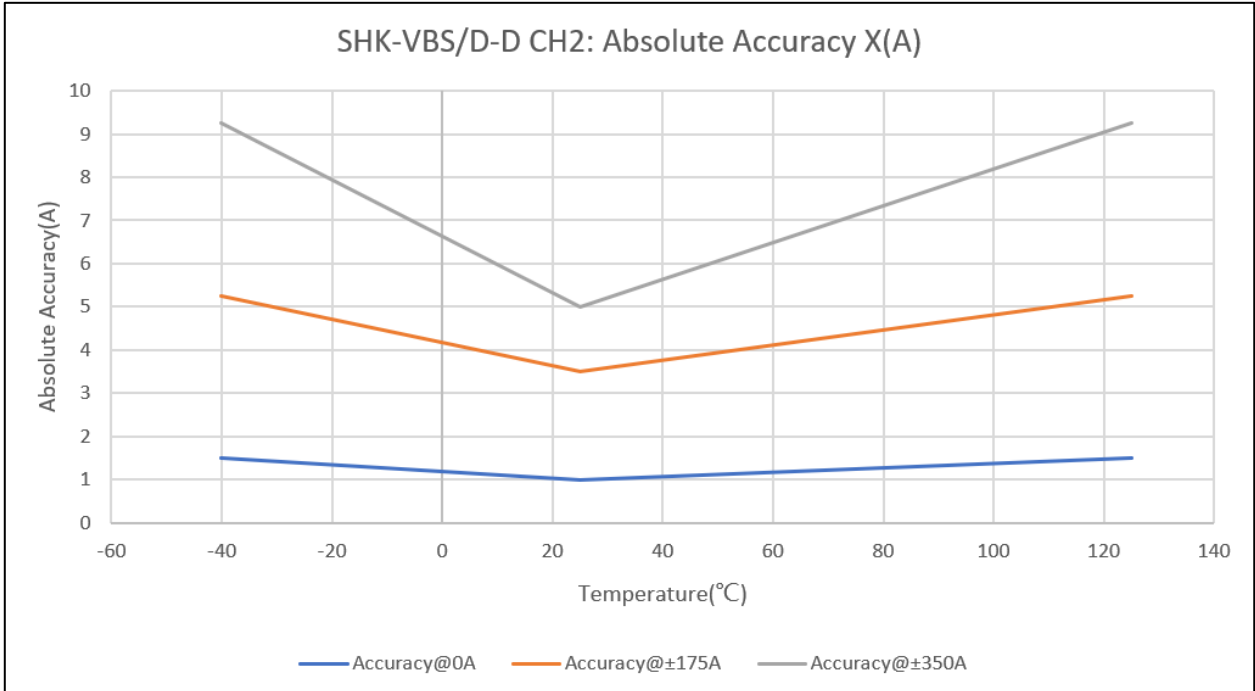

6. Electrical data SHK-VBS/D-E

Condition: Vcc = 5.0 V, T_A = 25°C, unless specified.

Parameters	Symbol	Unit	Min.	Typ.	Max.	Remark
Primary current	I _{pn}	A	-40		40	CH1
			-400		400	CH2
Supply voltage	V _{cc}	V	4.75	5	5.25	
Consumption current	I _{cc}	mA	21	28	35	
Full-scale output	V _{FS}	V		±2		(V _{out} @ ±I _{pn}) – V _{off}
Output resistance	R _{out}	kΩ		5		@V _{out}
Offset voltage	V _{off}	V	2.475	2.5	2.525	V _{cc} =5V
Theoretical gain	G _{th}	mV/A		50		CH1
				5		CH2
Non-linearity	Non-L	%I _{pn}	-1	0.5	1	±I _{pn}
Step response time	t _{res}	μs		18	20	@90% of I _{PN}
-3dB band width	BW	kHz		10		Back-end non-RC circuit
Noise	V _{noise}	mVpp				
DC ~ 10 kHz				15		
DC ~ 100 kHz				20		

Note:

9. Accuracy @ RT, X = ((V_{out} @ I_n @ 25°C) – (G_{fit} * I_n + V_{off} @ 25°C)) / V_{FS}, Here I_n is the current test current. G_{fit} is the normal temperature fitting gain.

10. Accuracy, X_TRange = ((V_{out} @ I_n @ T_x) – (G_{fit}@25°C * I_n + V_{off} @ 25°C)) / V_{FS}, The fitting gain of the product at G_{fit}@25 °C is 25 °C.

Accuracy table: SHK-VBS/D-E CH1

Parameter	Symbol	Unit	Temperature					
			-40°C	-20°C	0°C	25°C	65°C	125°C
Accuracy@0A	X	A	0.35	0.29	0.23	0.15	0.23	0.35
Accuracy@±20A			1.20	0.98	0.77	0.50	0.80	1.20
Accuracy@±40A			1.50	1.25	1.01	0.70	1.02	1.50

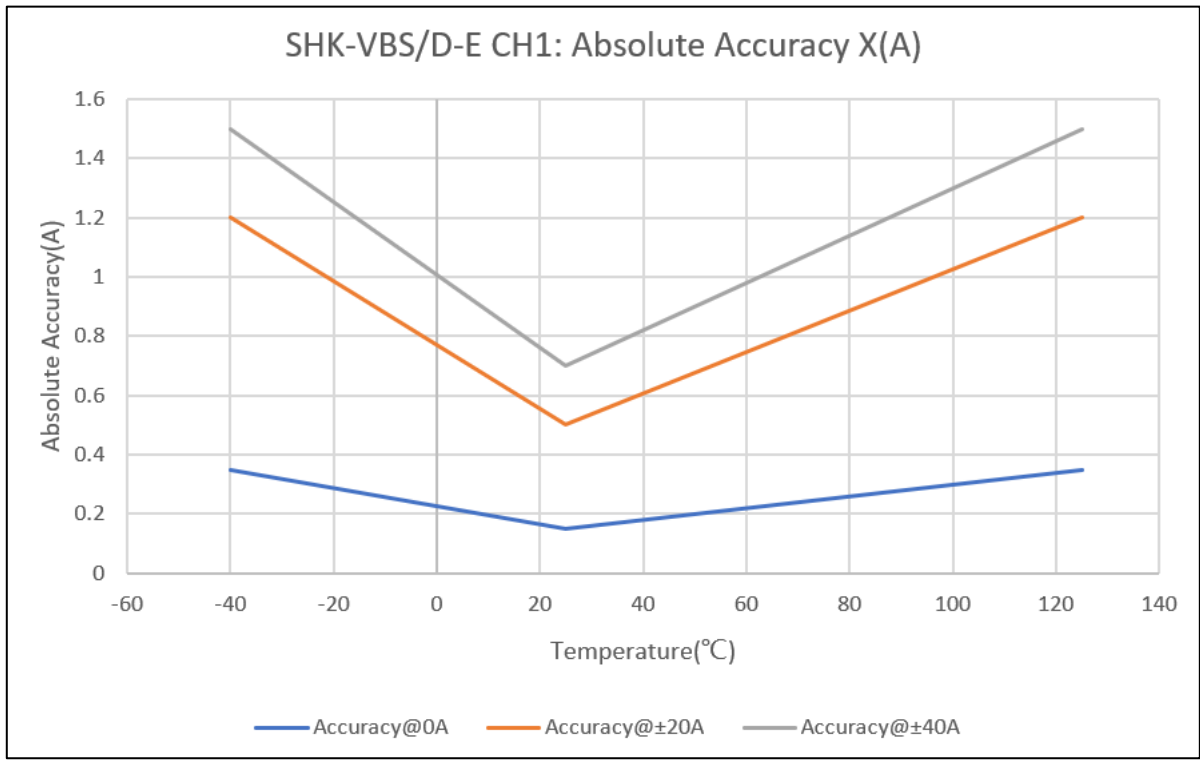

Accuracy table: SHK-VBS/D-E CH2

Parameter	Symbol	Unit	Temperature					
			-40°C	-20°C	0°C	25°C	65°C	125°C
Accuracy@0A	X	A	1.80	1.6	1.4	1.2	1.4	1.8
Accuracy@±200A			10.0	8.8	7.5	6.0	7.6	10.0
Accuracy@±400A			13.0	11.2	9.3	7.0	9.4	13.0

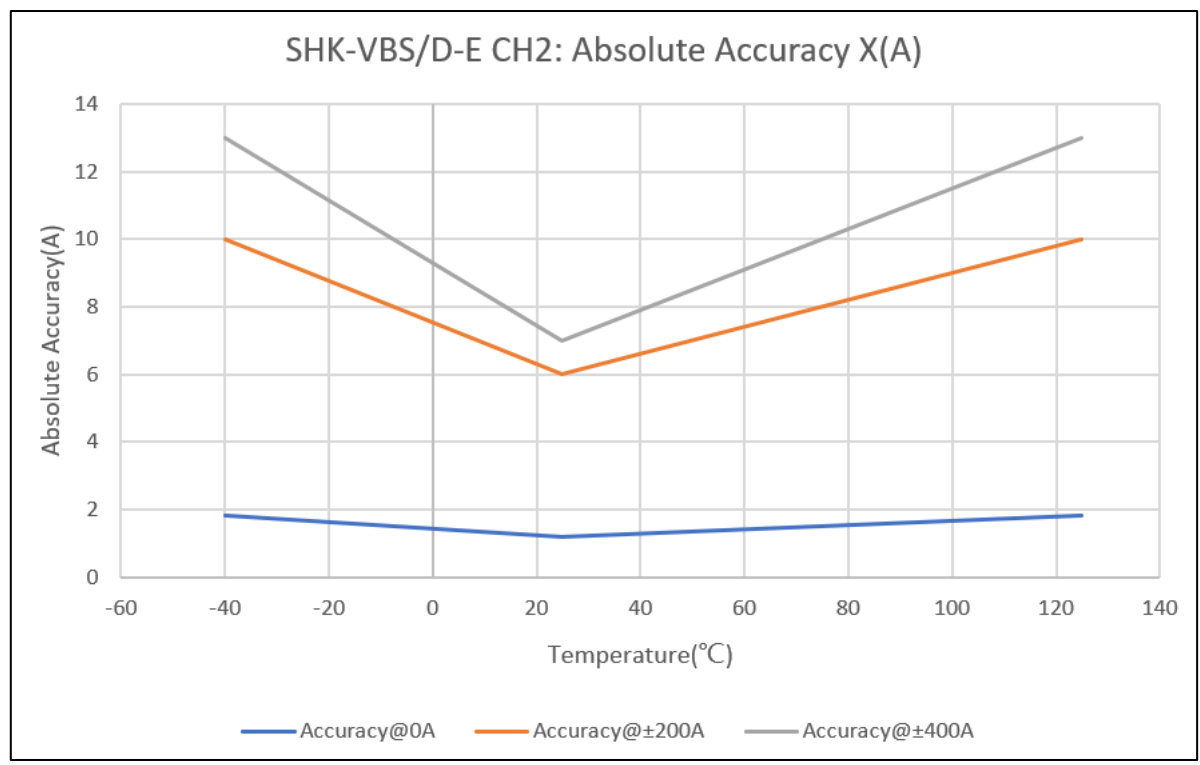

7. Electrical data SHK-VBS/D-H

Condition: Vcc = 5.0 V, T_A = 25°C, unless specified.

Parameters	Symbol	Unit	Min.	Typ.	Max.	Remark
Primary current	I _{pn}	A	-30		30	CH1
			-500		500	CH2
Supply voltage	V _{cc}	V	4.75	5	5.25	
Consumption current	I _{cc}	mA	21	28	35	
Full-scale output	V _{FS}	V		±2		(V _{out} @ ±I _{pn}) – V _{off}
Output resistance	R _{out}	kΩ		5		@V _{out}
Offset voltage	V _{off}	V	2.475	2.5	2.525	V _{cc} =5V
Theoretical gain	G _{th}	mV/A		66.7		CH1
				4		CH2
Non-linearity	Non-L	%I _{pn}	-1	0.5	1	±I _{pn}
Step response time	t _{res}	μs		18	20	@90% of I _{PN}
-3dB band width	BW	kHz		10		Back-end non-RC circuit
Noise	V _{noise}	mVpp				
DC ~ 10 kHz			15			
DC ~ 100 kHz				20		

Note:

11. Accuracy @ RT, X = ((V_{out} @ I_n @ 25°C) – (G_{fit} * I_n + V_{off} @ 25°C)) / V_{FS}, Here I_n is the current test current. G_{fit} is the normal temperature fitting gain.

12. Accuracy, X_TRange = ((V_{out} @ I_n @ T_x) – (G_{fit}@25°C * I_n + V_{off} @ 25°C)) / V_{FS}, The fitting gain of the product at G_{fit}@25°C is 25°C.

Accuracy table: SHK-VBS/D-H CH1

Parameter	Symbol	Unit	Temperature					
			-40°C	-20°C	0°C	25°C	65°C	125°C
Accuracy@0A	X	A	0.35	0.29	0.23	0.15	0.23	0.35
Accuracy@±20A			0.73	0.64	0.56	0.45	0.56	0.73
Accuracy@±30A			1.00	0.91	0.82	0.70	0.82	1.00

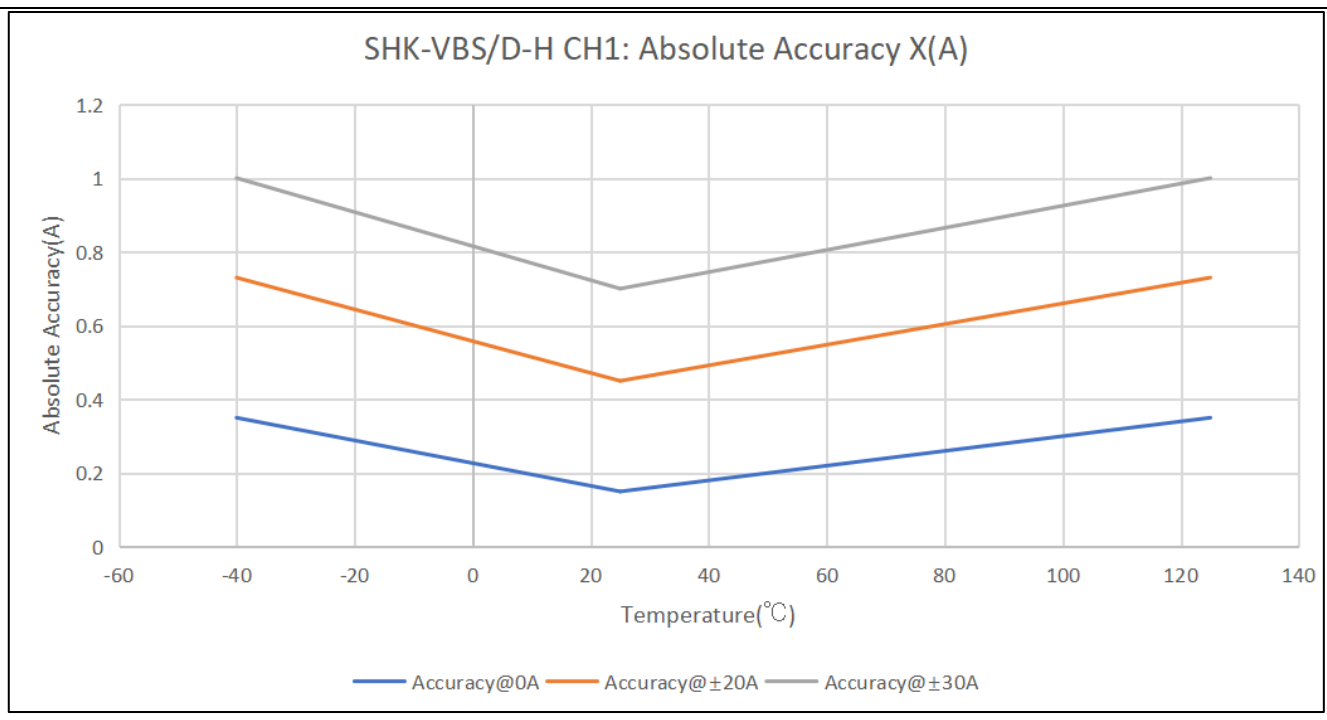

Accuracy table: SHK-VBS/D-H CH2

Parameter	Symbol	Unit	Temperature					
			-40°C	-20°C	0°C	25°C	65°C	125°C
Accuracy@0A	X	A	1.80	1.55	1.31	1.00	1.32	1.80
Accuracy@±250A			9.00	8.08	7.15	6.00	7.20	9.00
Accuracy@±500A			15.0	13.15	11.31	9.00	11.4	15.0

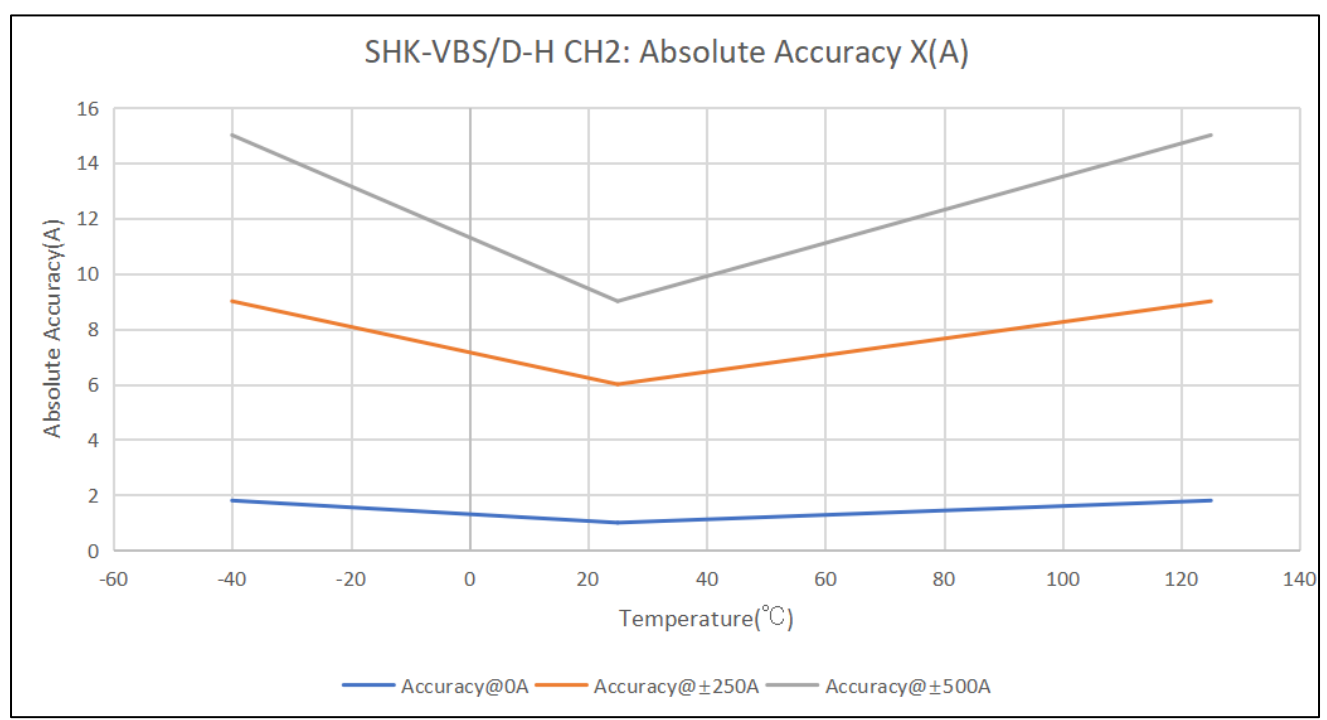

8. Electrical data SHK-VBS/D-J

Condition: Vcc = 5.0 V, T_A = 25°C, unless specified.

Parameters	Symbol	Unit	Min.	Typ.	Max.	Remark
Primary current	I _{pn}	A	-60		60	CH1
			-600		600	CH2
Supply voltage	V _{cc}	V	4.75	5	5.25	
Consumption current	I _{cc}	mA	21	28	35	
Full-scale output	V _{FS}	V		±2		(V _{out} @ ±I _{pn}) – V _{off}
Output resistance	R _{out}	kΩ		5		@V _{out}
Offset voltage	V _{off}	V	2.475	2.5	2.525	V _{cc} =5V
Theoretical gain	G _{th}	mV/A		33.333		CH1
				3.333		CH2
Non-linearity	Non-L	%I _{pn}	-1	0.5	1	±I _{pn}
Step response time	t _{res}	μs		18	20	@90% of I _{PN}
-3dB band width	BW	kHz		10		Back-end non-RC circuit
Noise	V _{noise}	mVpp				
DC ~ 10 kHz				15		
DC ~ 100 kHz				20		

Note:

13. Accuracy @ RT, X = ((V_{out} @ I_n @ 25°C) – (G_{fit} * I_n + V_{off} @ 25°C)) / V_{FS}, Here I_n is the current test current. G_{fit} is the normal temperature fitting gain.

14. Accuracy, X_TRange = ((V_{out} @ I_n @ T_x) – (G_{fit}@25°C * I_n + V_{off} @ 25°C)) / V_{FS}, The fitting gain of the product at G_{fit}@25°C is 25°C.

Accuracy table: SHK-VBS/D-J CH1

Parameter	Symbol	Unit	Temperature					
			-40°C	-20°C	0°C	25°C	65°C	125°C
Accuracy@0A	X	A	0.35	0.29	0.23	0.15	0.23	0.35
Accuracy@±30A			1.00	0.88	0.75	0.6	0.84	1.2
Accuracy@±60A			1.90	1.65	1.41	1.10	1.60	2.35

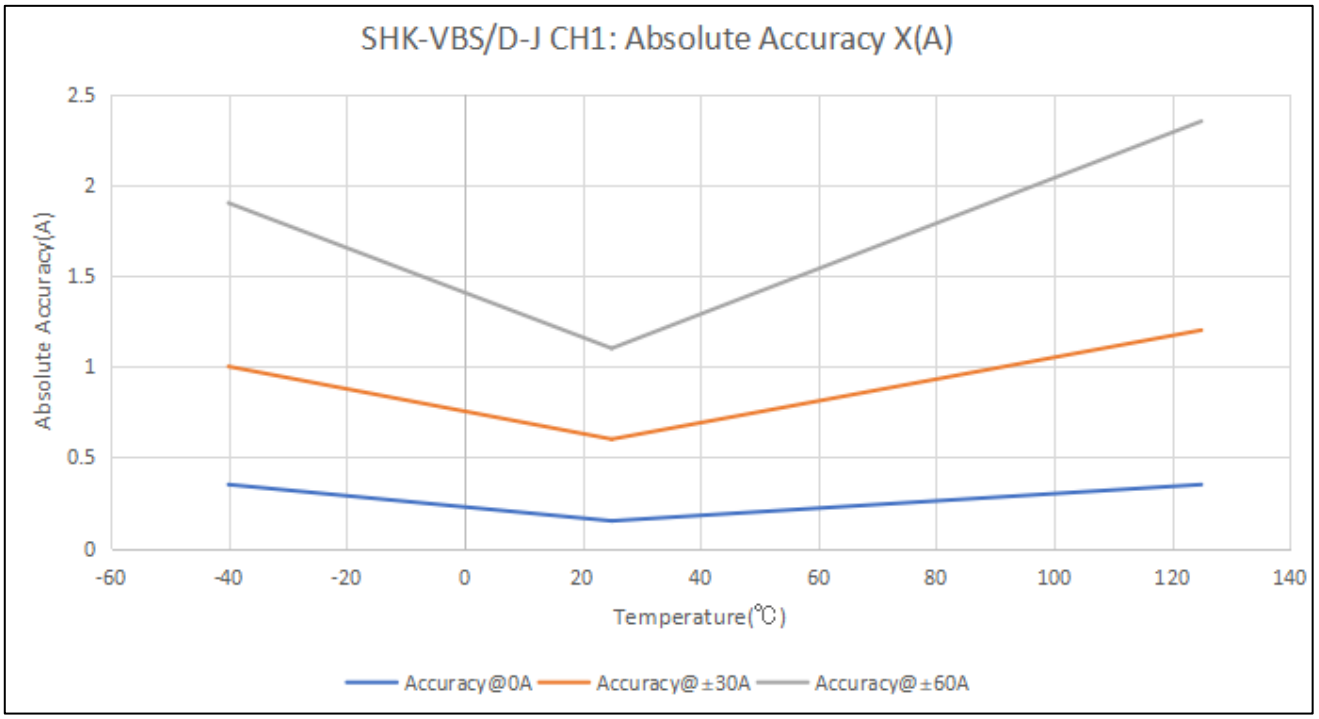

Accuracy table: SHK-VBS/D-J CH2

Parameter	Symbol	Unit	Temperature					
			-40°C	-20°C	0°C	25°C	65°C	125°C
Accuracy@0A	X	A	2.30	2.05	1.80	1.50	1.62	1.80
Accuracy@±300A			10.80	9.69	8.58	7.20	8.64	10.80
Accuracy@±600A			18.00	15.79	13.57	10.80	14.68	20.00

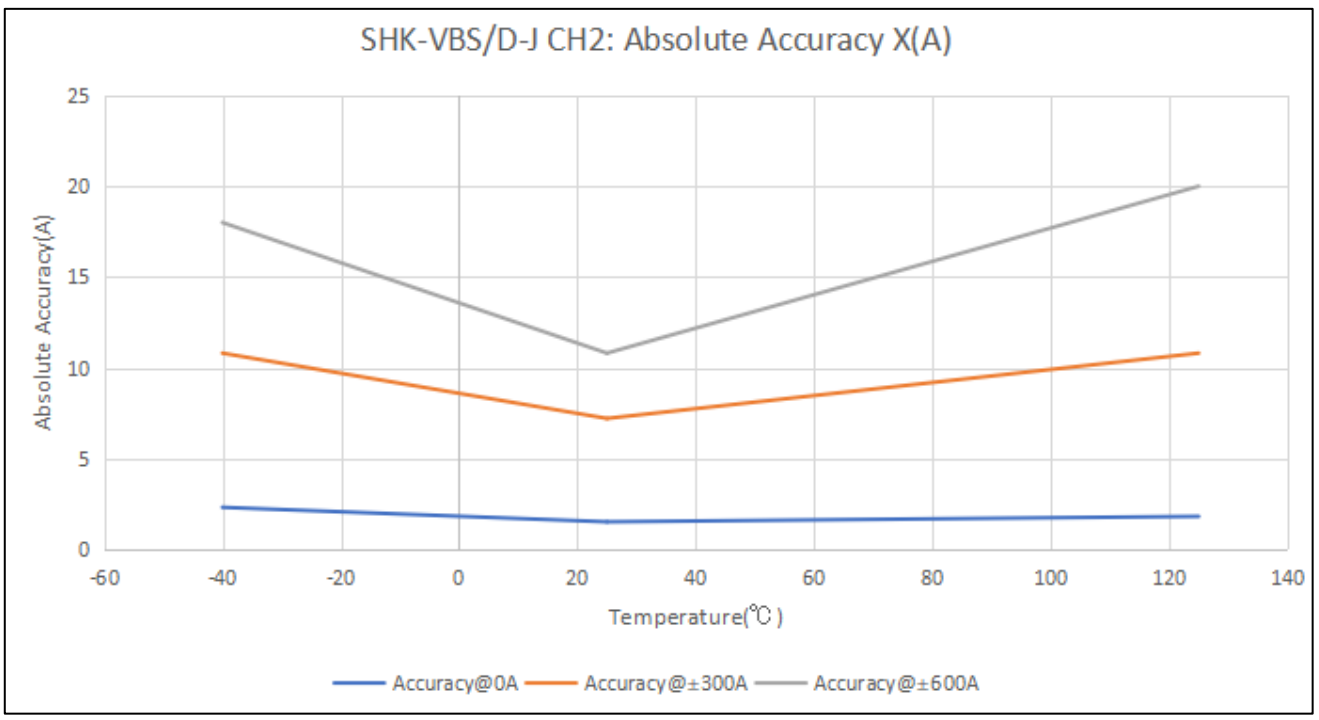

9. Frequency band width

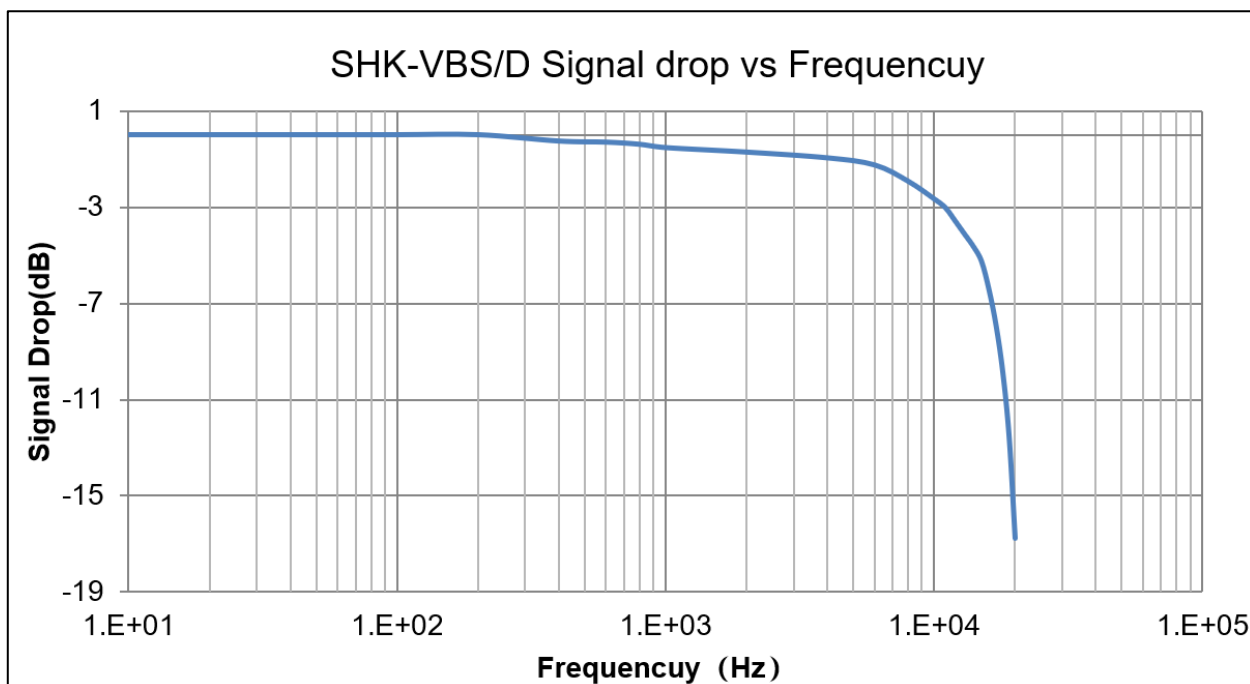
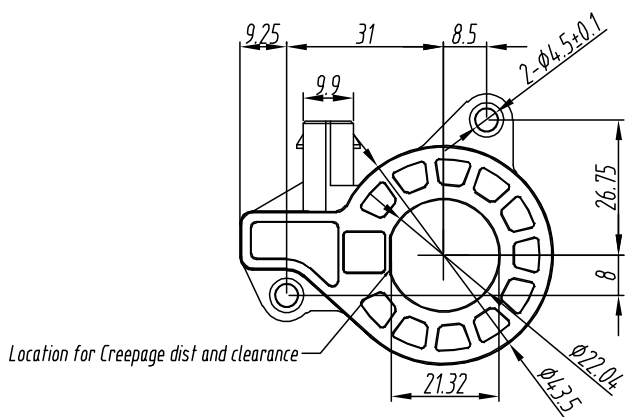
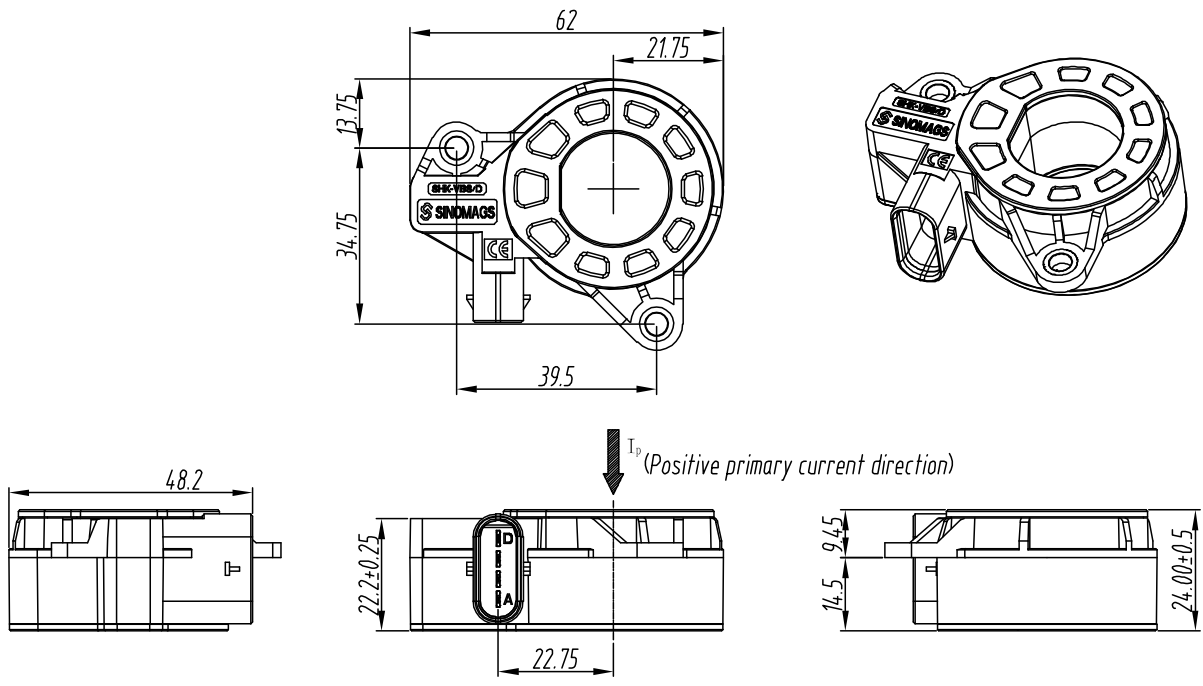

Fig.1 the band width of SHK-VBS/D series current sensors. The bandwidth of the sensor is in the range of DC ~10 kHz (-3 dB).

10. SHK-VBS/D Dimensions & Pins & Footprint



- Mechanical characteristics**
- Plastic case >PBT-GF30<
 - Magnetic core Channel 1: FeNi alloy
Channel 2: FeNi allo
 - Electrical terminal coating Brass tin plated
 - Degrees of protection provided by enclosure IP6K9K

ELECTRICAL DIAGRAM

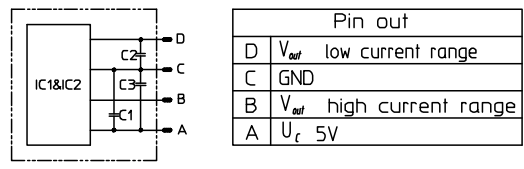

Material : Fit UL94V-0 & RoHS requirements ;
General tolerance : ±0.5
Unit :mm

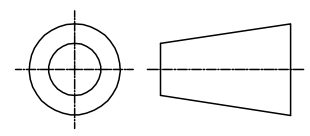

Mounting recommendation:

- Mating connector P/N TYCO 1-1456426-5
- Max assembly torque 2.5 N m(for M4 × 0.7mm)
- Clamping force must be applied on the compression limiter



11. Typical application

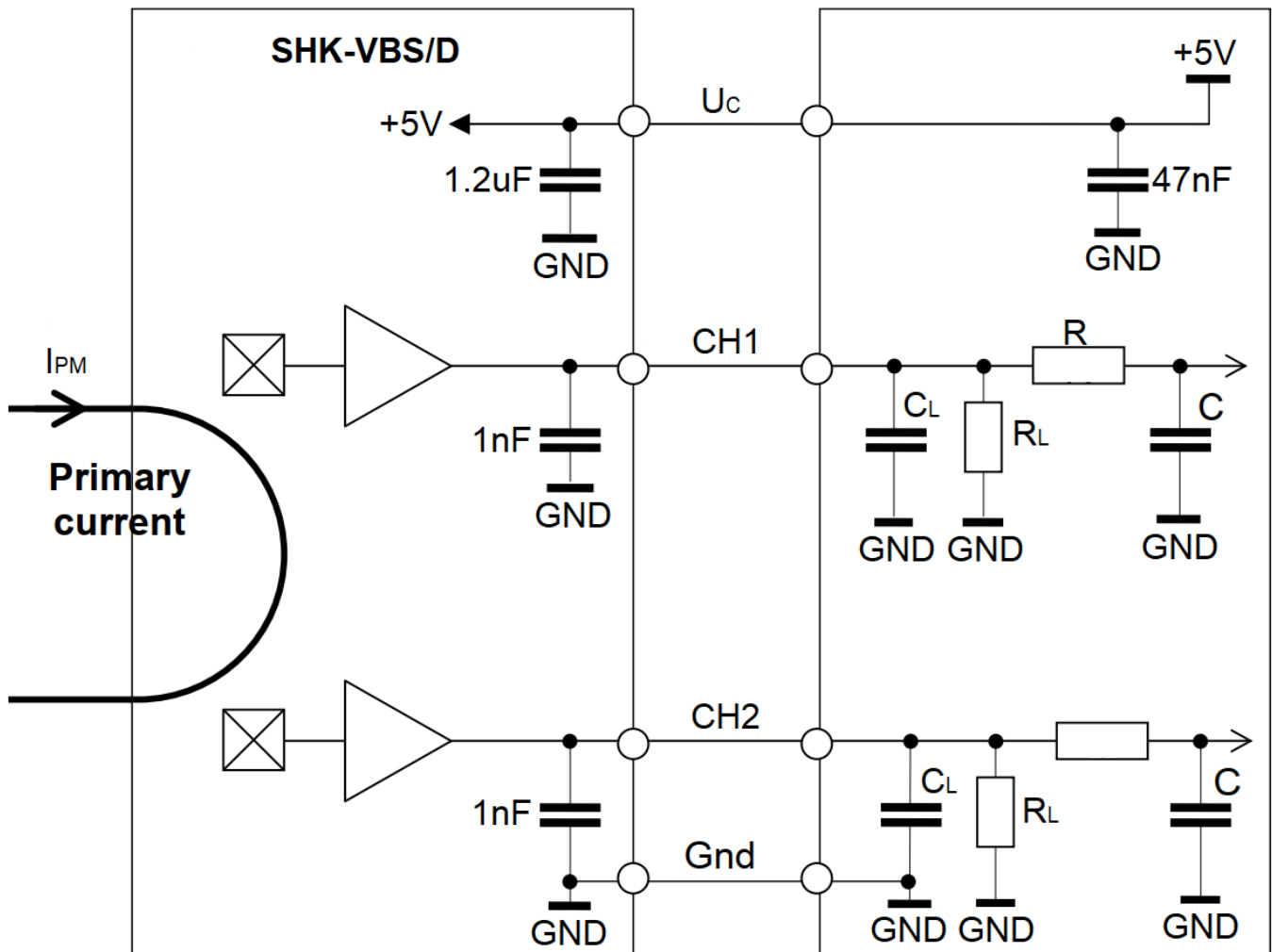

Notes:

1. $R_L > 10k\Omega$ optional resistor for signal line diagnostic;
2. $C_L < 10nF$ EMC protection;
3. R_C Low pass filter EMC protection(optional);