



CURRENT SENSOR

PRODUCT SERIES: STB-LF
STB-100LF
PRODUCT PART NUMBER: STB-200LF
STB-200LF-B
VERSION: Ver 1.4



Sinomags Technology Co., Ltd.

Web site: www.sinomags.com

CONTENT

1.	Description	2
2.	STB-100LF Electrical parameters	3
3.	STB-200LF Electrical parameters	4
4.	STB-200LF-B Electrical parameters	5
5.	Dimensions: STB-100&200LF	6
6.	Dimensions: STB-200LF-B	7

1. Description

STB-LF series current sensors are based on close loop principle. The sensor can detect the current with DC, AC, pulse and irregular wave shape with current output.

Typical application

- Windmill inverters
- Test and measurement
- Battery supplied applications
- Static converters for DC motors drives
- AC variable speed and servo motor drives
- Switched model power supplies (SMPS)
- UPS

General parameters

Parameter	Symbol	Unit	Value
Sensor operating temperature	T_A	°C	-40 ~ 85
Storage temperature	T_S	°C	-50 ~ 90
Mass	m	g	75

Absolute parameters

Parameters	Symbol	Unit	Value
Supply voltage (-40°C...85°C)	$V_{CC_{max}}$	V	± 15.75
Maximum primary conductor temperature	$T_{B_{max}}$	°C	100
Maximum steady state primary current (-40°C...85°C)	$I_{PN_{max}}$	A	1000

Ratings

Parameter	Unit	Value
Primary involved potential	V AC/DC	1500
Maximum surrounding air temperature	°C	85
Primary current	A	STB-100LF:0...100 STB-200LF:0...200 STB-200LF-B:0...200

Isolation parameters

Parameter	Symbol	Unit	Value	Remark
RMS voltage for AC test 50Hz/1 min	U_d	kV	4	
Impulse withstand voltage 1.2/50µs	U_W	kV	8	
Clearance distance (pri. -sec)	dCl	mm	10.2	Shortest distance through air
Creepage distance (pri. -sec)	dCp	mm	11	Shortest path along device body
Case material	-	-	V0	According to UL 94
Comparative tracking index	CTI		600	

2. STB-100LF Electrical parameters

Condition: $V_{CC} = \pm 15V$, $T_A = 25^\circ C$, $R_M = 1\Omega$ unless specified.

Parameters	Symbol	Unit	Min	Typ	Max	Remark
Primary nominal RMS current	I_{PN}	A			100	
Primary current measuring range	I_{PM}	A	-200		200	$V_{CC} = \pm 15V$
Secondary nominal RMS current	I_{SN}	A	-0.1		0.1	
Secondary current	I_S	A	-0.2		0.2	
Resistance of secondary winding	R_S	Ω			8.5	
Supply voltage	V_{CC}	V	± 11.4		± 15.75	
Current consumption	I_{CC}	mA		$14 + I_S$ $18 + I_S$		$V_{CC} = \pm 12V$ $V_{CC} = \pm 15V$
Turns ratio	N_S	NT		1000		
Nominal sensitivity	S_N	mA/A		1		
Offset current	I_{OE}	mA	-0.15		0.15	
Offset current temperature drift	I_{OT}	mA	-0.2		0.2	$-40^\circ C \sim 85^\circ C$
Sensitivity error	ε_S	%	-0.15		0.15	
Linearity error	ε_L	% of I_{PN}	-0.05		0.05	
RMS noise current referred to pri.	I_{NO}	mA		20		1Hz to 100kHz
Delay time @ 10 % of I_{PN}	t_{d10}	μs		0.5		
Delay time @ 90 % of I_{PN}	t_{d90}	μs		0.5		
-3 dB band width	BW	kHz		100		
Total error at I_{PN}	ε_{tot}	% of I_{PN}	-0.2		0.2	$-40^\circ C \dots 85^\circ C$

3. STB-200LF Electrical parameters

Condition: $V_{CC} = \pm 15V$, $T_A = 25^\circ C$, $R_M = 1\Omega$ unless specified.

Parameters	Symbol	Unit	Min	Typ	Max	Remark
Primary nominal RMS current	I_{PN}	A			200	
Primary current measuring range	I_{PM}	A	-420		420	$V_{CC} = \pm 15V$
Secondary nominal RMS current	I_{SN}	A	-0.1		0.1	
Secondary current	I_S	A	-0.21		0.21	
Resistance of secondary winding	R_S	Ω			27	
Supply voltage	V_{CC}	V	± 11.4		± 15.75	
Current consumption	I_{CC}	mA		$14 + I_S$ $18 + I_S$		$V_{CC} = \pm 12V$ $V_{CC} = \pm 15V$
Turns ratio	N_S	NT		2000		
Nominal sensitivity	S_N	mA/A		0.5		
Offset current, referred to primary	I_{OE}	A	-0.15		0.15	
Temperature variation of I_{OE} , referred to primary	I_{OT}	A	-0.2		0.2	$-40^\circ C \sim 85^\circ C$
Magnetic offset current (@ $3 \times I_{PN}$), referred to primary	I_{OM}	A		± 0.2		
Sensitivity error	ε_S	%	-0.1		0.1	
Linearity error	ε_L	% of I_{PN}	-0.05		0.05	
RMS noise current referred to pri.	I_{NO}	mA		20		1Hz to 100kHz
Delay time @ 10 % of I_{PN}	t_{d10}	μs		0.5		
Delay time @ 90 % of I_{PN}	t_{d90}	μs		0.5		
-3 dB band width	BW	kHz		100		
Total error at I_{PN}	ε_{tot}	% of I_{PN}	-0.2		0.2	$-40^\circ C \dots 85^\circ C$

4. STB-200LF-B Electrical parameters

Condition: $V_{CC} = \pm 15V$, $T_A = 25^\circ C$, $R_M = 1\Omega$ unless specified.

Parameters	Symbol	Unit	Min	Typ	Max	Remark
Primary nominal RMS current	I_{PN}	A			200	
Primary current measuring range	I_{PM}	A	-420		420	$V_{CC} = \pm 15V$
Secondary nominal RMS current	I_{SN}	A	-0.1		0.1	
Secondary current	I_S	A	-0.21		0.21	
Resistance of secondary winding	R_S	Ω			27	
Supply voltage	V_{CC}	V	± 11.4		± 15.75	
Current consumption	I_{CC}	mA		$14 + I_S$ $18 + I_S$		$V_{CC} = \pm 12V$ $V_{CC} = \pm 15V$
Turns ratio	N_S	NT		2000		
Nominal sensitivity	S_N	mA/A		0.5		
Offset current	I_{OE}	mA	-0.15		0.15	$I_P = 0$ $T_A = 25^\circ C$
Temperature variation of I_{OE}	I_{OT}	A	-0.2		0.2	$-40^\circ C \sim 85^\circ C$
Magnetic offset current (@ $3 \times I_{PN}$)	I_{OM}	A	-0.1		0.1	
Sensitivity error	ε_S	%	-0.1		0.1	
Linearity error	ε_L	% of I_{PN}	-0.1		0.1	
RMS noise current referred to pri.	I_{NO}	mA		20		1Hz to 100kHz
Delay time @ 10 % of I_{PN}	t_{d10}	μs		0.5		
Delay time @ 90 % of I_{PN}	t_{d90}	μs		0.5		
-3 dB band width	BW	kHz		100		
Total error at I_{PN}	ε_{tot}	% of I_{PN}	-0.4		0.4	$-40^\circ C \dots 85^\circ C$

5. Dimensions: STB-100&200LF

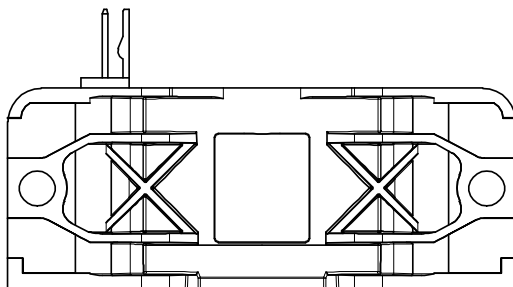
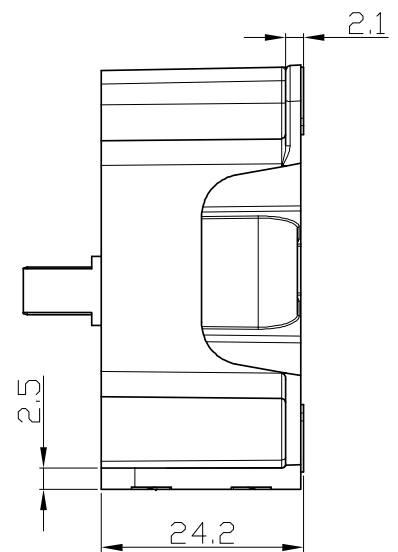
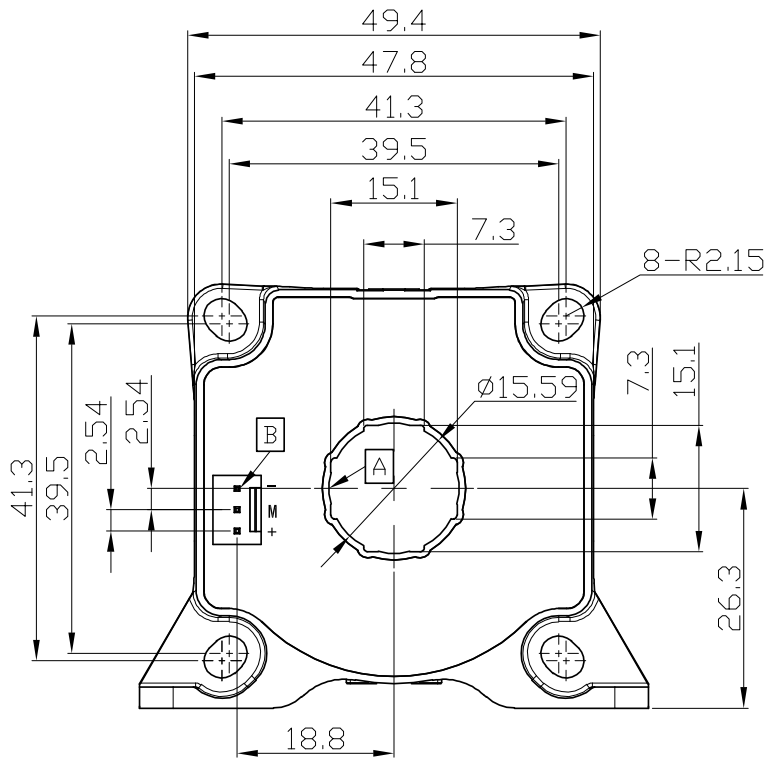
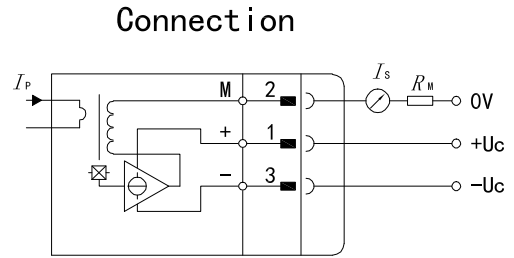
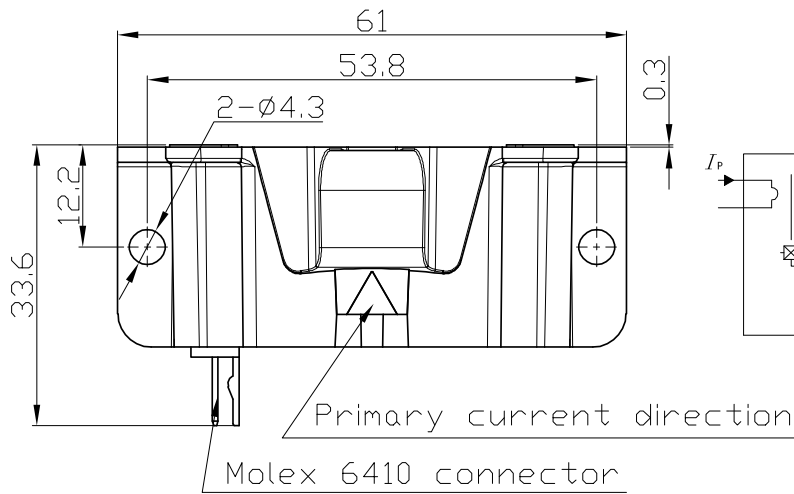

Material : Fit UL94V-0 & RoHS requirements ;
General tolerance : ± 0.5
Unit :mm

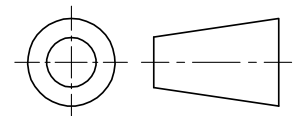

6. Dimensions: STB-200LF-B

