

Current Sensor

Product Series: STK-616AM5

Part number: STK-616A-20ML5B5
STK-616A-25ML5B5
STK-616A-40ML5B5
STK-616A-50ML5B5
STK-616A-60ML5B5
STK-616A-80ML5B5
STK-616A-100ML5B5
STK-616A-120ML5B5
STK-616A-166ML5B5
STK-616A-180ML5B5
STK-616A-200ML5B5
STK-616A-25ML5B3
STK-616A-50ML5B3
STK-616A-55ML5B3
STK-616A-60ML5B3
STK-616A-80ML5B3
STK-616A-100ML5B3
STK-616A-50ML5U5
STK-616A-80ML5U3
STK-616A-100ML5U3

Version: Ver 2.8

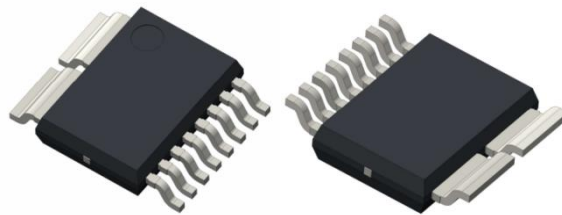

Sinomags Technology Co., Ltd

Web site: www.sinomags.com

CONTENT

1. Description.....	2
2. Part number definition.....	4
3. Temperature vs Current	4
4. Electrical data STK-616A-XXML5B5.....	5
5. Electrical data STK-616A-XXML5B3.....	7
6. Electrical data STK-616A-XXML5U3.....	8
7. Electrical data STK-616A-XXML5U5.....	9
8. Dimensions.....	10
9. Pin definitions.....	10
10. PCB layout recommendation.....	11
11. Frequency band width.....	11
12. Step response time.....	12
13. Block diagram.....	12
14. Typical application circuit.....	13
15. OCD function for STK-616A-25ML5B5.....	13
16. OCD function for STK-616A-50ML5B5.....	14
17. OCD function for STK-616A-80ML5B5.....	14
18. General information on OCD.....	15
19. PACKAGE MATERIALS INFORMATION	16

1. Description

The STK-616AM5 series current sensor is based on TMR (tunnel magnetoresistance) technology and open-loop design. It is suitable for DC, AC pulsed and any kind of irregular current measurement under the isolated conditions. The STK-616AM5 series current sensor has built in OCD (Over Current Detection) function. The primary conductor has very low resistance of 0.27 mΩ.

- The product is packaged in standard SOIC10 form.
- AEC-Q100, automotive qualified.

Typical applications

- AC Variable speed driver
- AC/DC, DC/DC power supply
- PV inverter
- Servo motor driver

General parameter

Parameter	Symbol	Unit	Value
Junction temperature	T_A	°C	-40 ~ 125
Storage temperature	T_stg	°C	-40 ~ 125
Mass	m	g	0.65

Absolute maximum rating

Parameter	Symbol	Unit	Value
Supply voltage	Vcc	V	6.5
ESD rating (HBM)	U_ESD	kV	4
Junction temperature	T_J	°C	150

Remark: the unrecoverable damage may occur when the product works on the conditions over the absolute maximum ratings. Long-time working on the absolute maximum ratings may cause the degradation on performance and reliability.

Isolation parameter

Parameter	Symbol	Unit	Value	Comment
RMS voltage for AC test 50 Hz, 1 min	Ud	kV	5	
Impulse withstand voltage 1.2/50μs	Ūw	kV	6	
Clearance distance (pri. -sec)	dCl	mm	8.5	Determined by customer's layout.
Creepage distance (pri. -sec)	dCp	mm	8.5	

Measuring current table

Part number	Current Range	Sensitivity (mV/A)	T (°C)
STK-616A-20ML5B5-0-2.5-X-X-X-R-X	±20 A	100	-40 ~ 125
STK-616A-25ML5B5-1-2.5-E-1-C-N-1	±25 A	80	-40 ~ 125

STK-616A-25ML5B5-1-2.5-E-2-C-N-1	±25 A	80	-40 ~ 125
STK-616A-25ML5B5-1-2.5-E-3-C-N-1	±25 A	80	-40 ~ 125
STK-616A-40ML5B5-0-2.5-X-X-X-R-X	±40 A	50	-40 ~ 125
STK-616A-50ML5B5-1-2.5-E-2-C-N-1	±50 A	40	-40 ~ 125
STK-616A-60ML5B5-1-2.5-E-3-C-N-1	±60 A	33.3	-40 ~ 125
STK-616A-80ML5B5-1-2.5-E-3-C-N-1	±80 A	25	-40 ~ 125
STK-616A-100ML5B5-1-2.5-E-3-C-N-1	±100 A	20	-40 ~ 125
STK-616A-120ML5B5-1-2.5-E-1-B-N-2	±120 A	16.7	-40 ~ 125
STK-616A-120ML5B5-1-2.5-E-3-B-N-2	±120 A	16.7	-40 ~ 125
STK-616A-166ML5B5-0-2.5-X-X-X-R-X	±166 A	12	-40 ~ 125
STK-616A-180ML5B5-1-2.5-E-3-C-N-1	±180 A	11	-40 ~ 125
STK-616A-200ML5B5-1-2.5-E-2-C-N-2	±200 A	10	-40 ~ 125
STK-616A-200ML5B5-1-2.5-E-1-C-N-2	±200 A	10	-40 ~ 125
STK-616A-25ML5B3-1-1.65-E-3-C-N-1	±25 A	52.8	-40 ~ 125
STK-616A-50ML5B3-1-1.65-E-2-C-N-1	±50 A	26.4	-40 ~ 125
STK-616A-55ML5B3-1-1.65-E-2-C-N-1	±55 A	24	-40 ~ 125
STK-616A-60ML5B3-1-1.65-E-3-C-N-1	±60 A	22	-40 ~ 125
STK-616A-80ML5B3-1-1.65-E-3-C-N-1	±80 A	16.5	-40 ~ 125
STK-616A-100ML5B3-1-1.65-E-1-Z-N-1	±100 A	13.2	-40 ~ 125
STK-616A-50ML5U5-1-0.5-E-2-C-R-2	50 A	80	-40 ~ 125
STK-616A-80ML5U3-1-0.5-E-2-C-R-2	80 A	33	-40 ~ 125
STK-616A-100ML5U3-1-0.5-E-2-C-R-2	100 A	26.4	-40 ~ 125

2. Part number definition

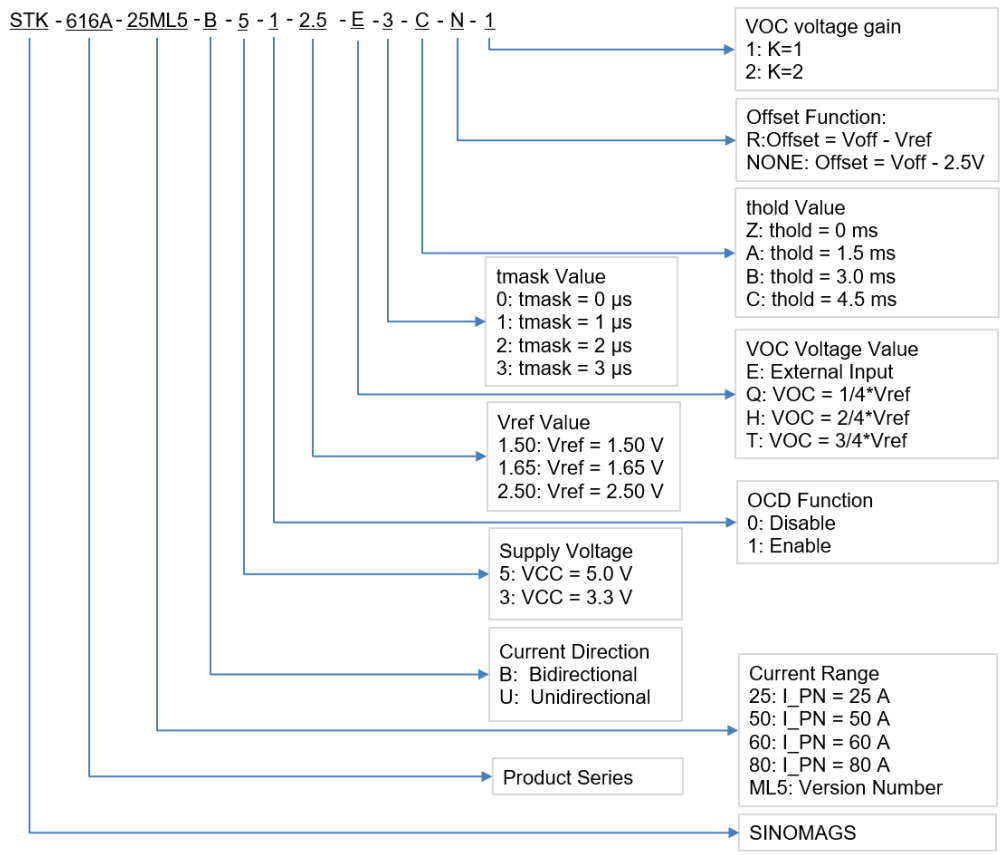

3. Temperature vs Current

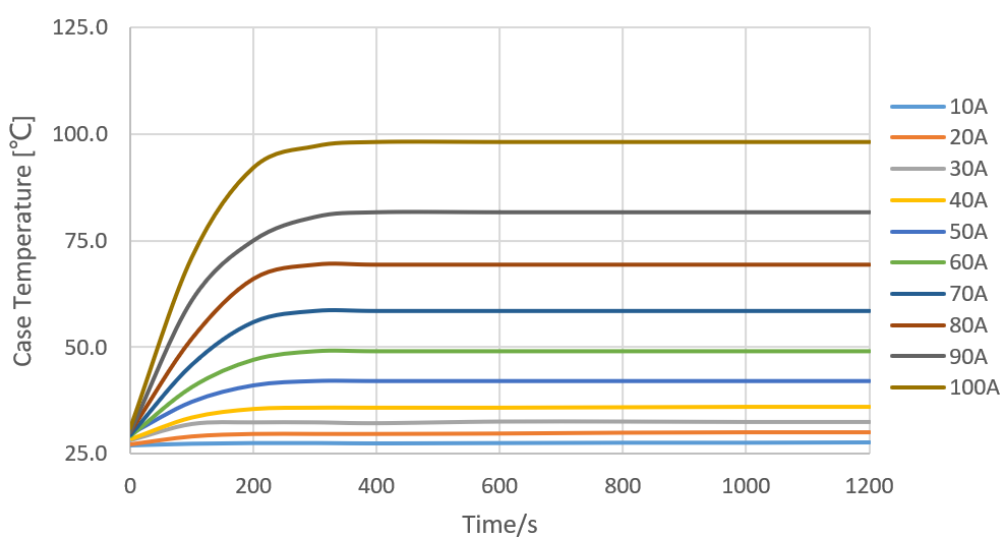

Figure 1. Relationship between STK-616AM5 Case temperature and amount of input current. Figure 1 shows the results of current & temperature measurement. Tested by using a standard demo test board, with 4 layers of copper conductors, where the thickness for each layer is 2 oz, the total thickness of demo board is 1.6 mm. This result is a reference data. Tc is changed much by the board layout and the heat dissipation. Please confirm it in your evaluation environment.

4. Electrical data STK-616A-XXML5B5

Condition: T_A = 25°C, V_{cc} = 5 V

Parameter	Symbol	Unit	Min	Typ	Max	Comment
Primary current measuring range	I _{pm}	A	-20		20	STK-616A-20ML5B5
			-25		25	STK-616A-25ML5B5
			-40		40	STK-616A-40ML5B5
			-50		50	STK-616A-50ML5B5
			-60		60	STK-616A-60ML5B5
			-80		80	STK-616A-80ML5B5
			-100		100	STK-616A-100ML5B5
			-120		120	STK-616A-120ML5B5
			-166		166	STK-616A-166ML5B5
			-180		180	STK-616A-180ML5B5
-200		200	STK-616A-200ML5B5			
Supply voltage	V _{cc}	V		5		
Current consumption	I _{cc}	mA		5	10	
Primary conductor resistance	R _{IP}	mΩ		0.27		
Quiescent voltage	V _{off}	V	2.45	2.50	2.55	V _{out} @ I _p = 0 A
Reference voltage	V _{ref}	V	2.45	2.50	2.55	
Internal output resistance	R _{out}	Ω		1		V _{out}
Theoretical gain (@ V _{off} = 2.5, Note 1)	G _{th}	mV/A		100		STK-616A-20ML5B5
				80		STK-616A-25ML5B5
				50		STK-616A-40ML5B5
				40		STK-616A-50ML5B5
				33.3		STK-616A-60ML5B5
				25		STK-616A-80ML5B5
				20		STK-616A-100ML5B5
				16.7		STK-616A-120ML5B5
				12		STK-616A-166ML5B5
				11		STK-616A-180ML5B5
	10		STK-616A-200ML5B5			
OCD function (if applicable)						
OCD range	VOC	V	0.3		3.3	K=1
			0.3		2	K=2
FAULT error		%		5%		% of OCD
OCD Hysteresis	IHYS	%		10%		% of OCD
OCD Fault Mask	tmask	μs		2		Note 3)
OCD Fault Mask error	Tmask_error	ns		125		



STK-616AM5 series current sensor

OCD Fault Hold Time	thold	ms		4.5		Note 4)
Accuracy performance						
Rated linearity @ 25°C	ξ	% of I _{pn}		±1.5		±I _{pn}
Step response time	t _{res}	μs		0.9		@90% of I _{pn}
Frequency bandwidth	BW	kHz		600		@ -3 dB
Output voltage noise	Vnoise	mVpp		10		DC ~ 600 kHz
Accuracy @ 25°C	X	% of I _{pn}		±1.5		@ 25°C
Thermal drift of G _{th}	GAIN _T	% of G _{th}		±1.5		@-40~105°C
Thermal drift of Voff	Voff _T	mV		±15		Drift related to the value @ 25°C
Total Accuracy	X _T	% of I _{pn}		±3.5		

Note:

- 1) The gain of the sensor should be calibrated in software level if an accurate measuring is required.
- 2) The default time for OCD Fault Mask Time is 3us, while it can be set as 0, 1, 2, 3 us per demand.
- 3) The default time for OCD Fault Hold Time is 4.5ms, while it can be set as 0, 1.5, 3, 4.5ms per demand.

5. Electrical data STK-616A-XXML5B3

Condition: $T_A = 25^\circ\text{C}$, $V_{CC} = 3.3\text{ V}$

Parameter	Symbol	Unit	Min	Typ	Max	Comment
Primary current measuring range	I_{pm}	A	-25		25	STK-616A-25ML5B3
			-50		50	STK-616A-50ML5B3
			-55		55	STK-616A-55ML5B3
			-60		60	STK-616A-60ML5B3
			-80		80	STK-616A-80ML5B3
			-100		100	STK-616A-100ML5B3
Supply voltage	V_{CC}	V		3.3		
Current consumption	I_{CC}	mA		5	10	
Primary conductor resistance	R_{IP}	m Ω		0.27		
Quiescent voltage	V_{off}	V	1.6	1.65	1.7	V_{out} @ $I_{pn} = 0\text{ A}$
Reference voltage	V_{ref}	V	1.6	1.65	1.7	
Internal output resistance	R_{out}	Ω		1		V_{out}
Theoretical gain (@ $V_{off} = 1.65$, Note 4)	G_{th}	mV/A		52.8		STK-616A-25ML5B3
				26.4		STK-616A-50ML5B3
				24		STK-616A-55ML5B3
				22		STK-616A-60ML5B3
				16.5		STK-616A-80ML5B3
				13.2		STK-616A-100ML5B3
OCD function (if applicable)						
OCD range	VOC	V	0.3		1.6	K=1
			0.3		1.6	K=2
FAULT error		%		5%		% of OCD
OCD Hysteresis	IHYS	%		10%		% of OCD
OCD Fault Mask	tmask	μs		2		Note 5)
OCD Fault Mask error	Tmask_error	ns		125		
OCD Fault Hold Time	thold	ms		4.5		Note 6)
Accuracy performance						
Rated linearity @ 25°C	ξ	% of I_{pn}		± 1.5		$\pm I_{pn}$
Step response time	t_{res}	μs		0.9		@90% of I_{pn}
Frequency bandwidth	BW	kHz		600		@ -3 dB
Output voltage noise	V_{noise}	mVpp		10		DC ~ 600 kHz
Accuracy @ 25°C	X	% of I_{pn}		± 1.5		@ 25°C
Thermal drift of G_{th}	GAIN_T	% of G_{th}		± 1.5		@ $-40\sim 105^\circ\text{C}$
Thermal drift of V_{off}	V_{off_T}	mV		± 15		Drift related to the

Total Accuracy	X_T	% of I _{pn}		±3.5		value @ 25°C
----------------	-----	----------------------	--	------	--	--------------

Note:

- 4) The gain of the sensor should be calibrated in software level if an accurate measuring is required.
- 5) The default time for OCD Fault Mask Time is 3 us, while it can be set as 0, 1, 2, 3 us per demand.
- 6) The default time for OCD Fault Hold Time is 4.5 ms, while it can be set as 0, 1.5, 3, 4.5 ms per demand.

6. Electrical data STK-616A-XXML5U3

Condition: T_A = 25°C, V_{cc} = 3.3 V

Parameter	Symbol	Unit	Min	Typ	Max	Comment
Primary current measuring range	I _{pm}	A	0		80	STK-616A-80ML5U3
			0		100	STK-616A-100ML5U3
Supply voltage	V _{cc}	V		3.3		
Current consumption	I _{cc}	mA		5	10	
Primary conductor resistance	R _{IP}	mΩ		0.27		
Quiescent voltage	V _{off}	V	0.45	0.5	0.55	V _{out} @ I _{pn} = 0 A
Reference voltage	V _{ref}	V	0.45	0.5	0.55	
Internal output resistance	R _{out}	Ω		1		V _{out}
Theoretical gain (@V _{off} = 1.65, Note 4)	G _{th}	mV/A		33		STK-616A-80ML5U3
				26.4		STK-616A-100ML5U3
OCD function (if applicable)						
OCD range	V _{OC}	V	0.3		1.6	K=1
			0.3		1.6	K=2
FAULT error		%		5%		% of OCD
OCD Hysteresis	I _{HYS}	%		10%		% of OCD
OCD Fault Mask	t _{mask}	μs		2		Note 5)
OCD Fault Mask error	T _{mask_error}	ns		125		
OCD Fault Hold Time	t _{hold}	ms		4.5		Note 6)
Accuracy performance						
Rated linearity @ 25°C	ξ	% of I _{pn}		±1.5		±I _{pn}
Step response time	t _{res}	μs		0.9		@90% of I _{pn}
Frequency bandwidth	BW	kHz		600		@ -3 dB
Output voltage noise	V _{noise}	mV _{pp}		10		DC ~ 600 kHz
Accuracy @ 25°C	X	% of I _{pn}		±1.5		@ 25°C
Thermal drift of G _{th}	G _{AIN_T}	% of G _{th}		±1.5		@ -40~105°C
Thermal drift of V _{off}	V _{off_T}	mV		±15		Drift related to the value @ 25°C
Total Accuracy	X_T	% of I _{pn}		±3.5		

Note:

- 7) The gain of the sensor should be calibrated in software level if an accurate measuring is required.

- 8) The default time for OCD Fault Mask Time is 3 us, while it can be set as 0, 1, 2, 3 us per demand.
- 9) The default time for OCD Fault Hold Time is 4.5 ms, while it can be set as 0, 1.5, 3, 4.5 ms per demand.

7. Electrical data STK-616A-XXML5U5

Condition: $T_A = 25^{\circ}\text{C}$, $V_{cc} = 5\text{ V}$

Parameter	Symbol	Unit	Min	Typ	Max	Comment
Primary current measuring range	I _{pn}	A	0		50	STK-616A-50ML5U5
			0		80	STK-616A-80ML5U5
			0		100	STK-616A-100ML5U5
Supply voltage	V _{cc}	V		5		
Current consumption	I _{cc}	mA		5	10	
Primary conductor resistance	R _{IP}	mΩ		0.27		
Quiescent voltage	V _{off}	V	0.45	0.5	0.55	V _{out} @ I _{pn} = 0A
Reference voltage	V _{ref}	V	0.45	0.5	0.55	
Internal output resistance	R _{out}	Ω		1		V _{out}
Theoretical gain (@V _{off} = 1.65, Note 4)	G _{th}	mV/A		80		STK-616A-50ML5U5
OCD function (if applicable)						
OCD range	VOC	V	0.3		3.3	K=1
			0.3		2	K=2
FAULT error		%		5%		% of OCD
OCD Hysteresis	I _{HYS}	%		10%		% of OCD
OCD Fault Mask	t _{mask}	μs		2		Note 5)
OCD Fault Mask error	T _{mask_error}	ns		125		
OCD Fault Hold Time	t _{hold}	ms		4.5		Note 6)
Accuracy performance						
Rated linearity @ 25°C	ξ	% of I _{pn}		±1.5		±I _{pn}
Step response time	t _{res}	μs		0.9		@90% of I _{pn}
Frequency bandwidth	BW	kHz		600		@ -3 dB
Output voltage noise	V _{noise}	mV _{pp}		10		DC ~ 600 kHz
Accuracy @ 25°C	X	% of I _{pn}		±1.5		@ 25°C
Thermal drift of G _{th}	G _{AIN_T}	% of G _{th}		±1.5		@ -40~105°C
Thermal drift of V _{off}	V _{off_T}	mV		±15		Drift related to the value @ 25°C
Total Accuracy	X _T	% of I _{pn}		±3.5		

Note:

- 10) The gain of the sensor should be calibrated in software level if an accurate measuring is required.
- 11) The default time for OCD Fault Mask Time is 3 us, while it can be set as 0, 1, 2, 3 us per demand.

12) The default time for OCD Fault Hold Time is 4.5 ms, while it can be set as 0, 1.5, 3, 4.5 ms per demand.

8. Dimensions

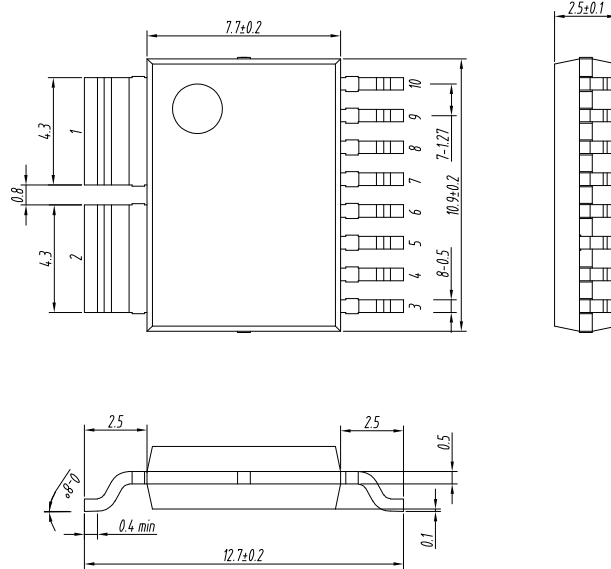

Figure 2. Dimensions of STK-616AM5 series current sensors. The unit is mm.

9. Pin definitions

PIN	Symbol	Description
1	IP+	Primary conductor pin (+)
2	IP-	Primary conductor pin (-)
3,10	GND	Ground pin (GND)
4	VREF	Reference pin, output function
5	FAULT	Over current detection alarm output, the pin is open leakage output
6	VOUT	Sensor output pin
7	VCC	Power supply pin
8	NC	NC
9	VOC	Over current detection threshold input pin

10. PCB layout recommendation

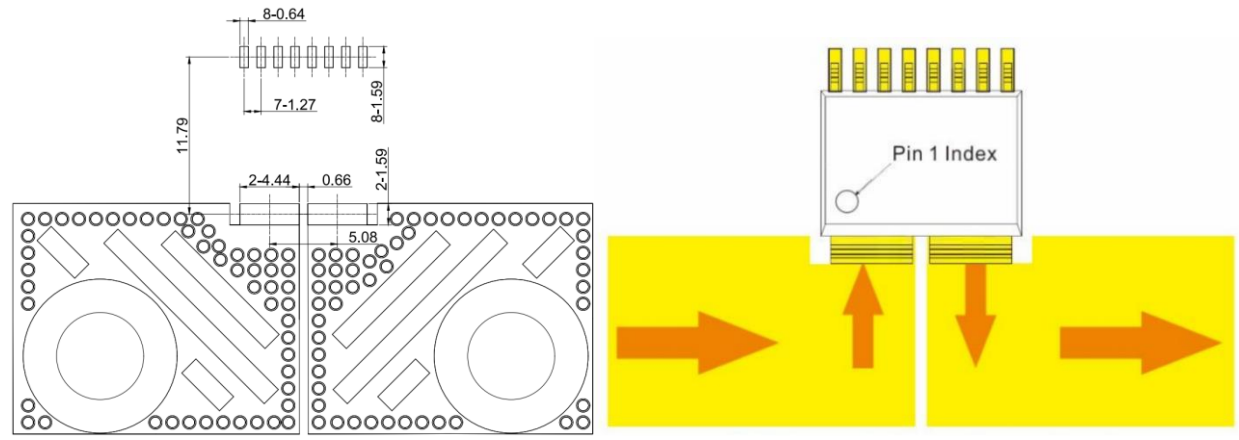

Figure 3. The recommended footprint of the SMT PCB layout for the STK-616AM5 series products. The unit is mm.

11. Frequency band width

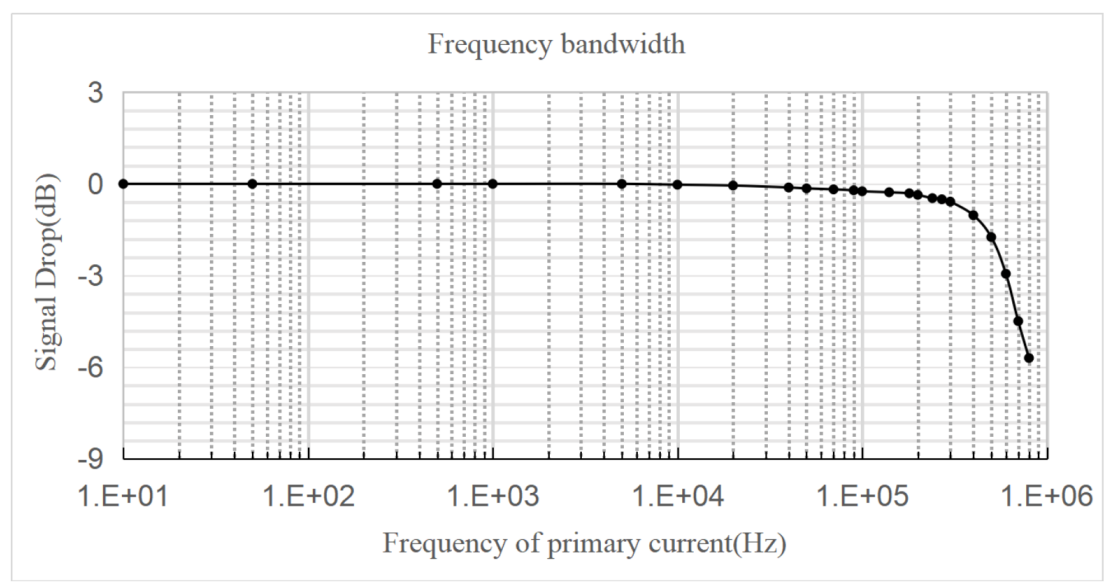

Figure 4 the frequency band width of the STK-616AM5 series products. the upper limit of the -3dB band width is 600 kHz.

12. Step response time

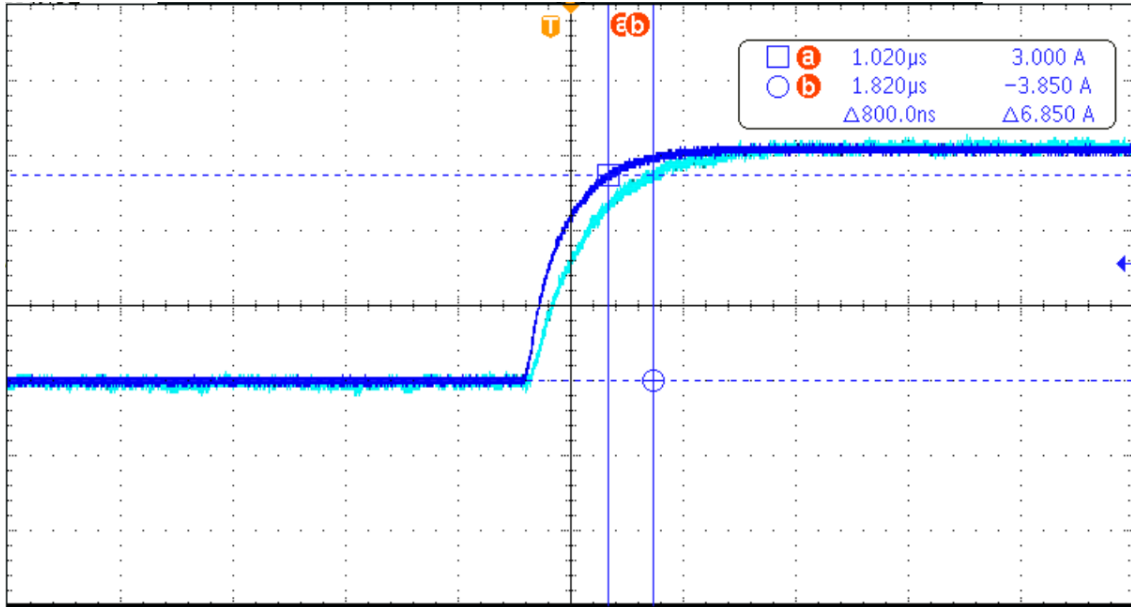

Figure 5. The typical frequency response of STK-616AM5 series current sensor. The response time from 90% of the primary current to 90% of the secondary output is 0.9µs.

13. Block diagram

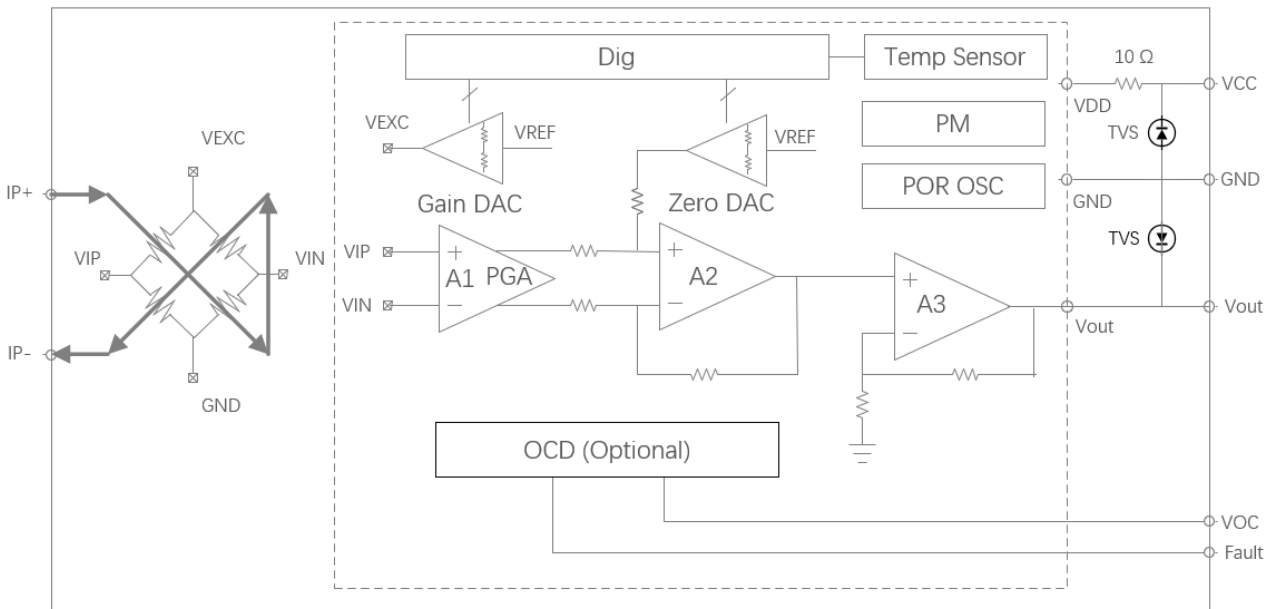

Figure 6. The functional block diagram for the STK-616AM5 series products.

14. Typical application circuit

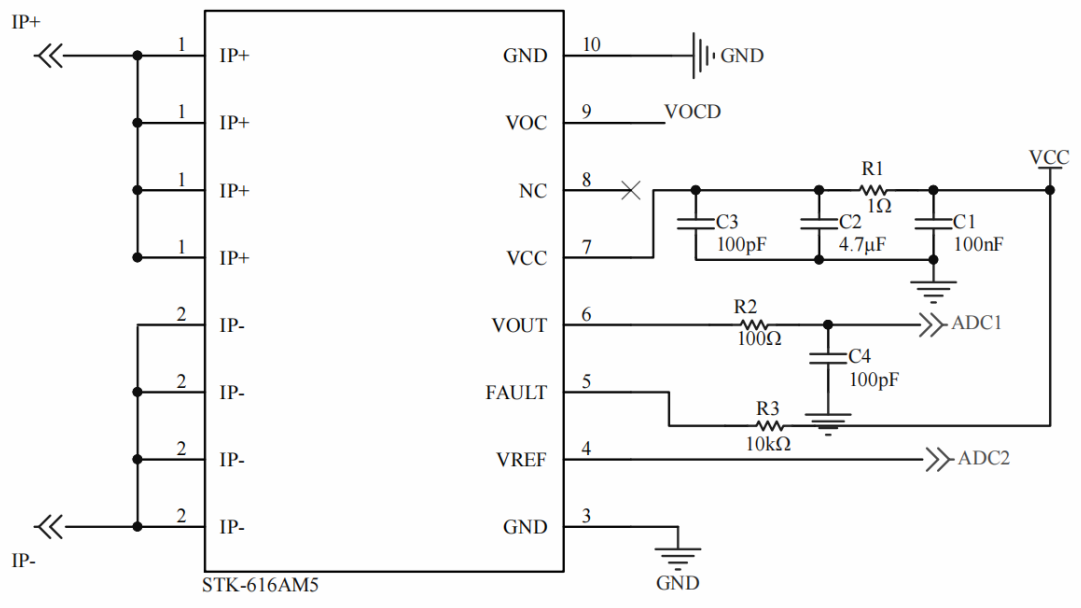

Figure 7. The reference application circuit for the STK-616AM5 series products.

Remark 1: R3 = 10 kΩ, recommended C1 = 100 nF, C2 = 4.7 μF, C3 = 100 pF, C4 = 100 pF. 100 pF of C3 and C4 does not affect the response speed of the chip. R2 and C4 constitute RC filter circuit ($f \approx 1/(2\pi RC)$). The bandwidth of STK-616AM6 is 600 kHz, and RC filter circuit above 600 kHz cannot realize a bandwidth above 600 kHz. If the VREF pin is not used, it can be left empty. If there is a need for an external capacitor, it is necessary to ensure that the capacitance value is greater than 100 nF.

Remark 2: The VREF and VOUT pins cannot be connected directly to a capacitor. If a capacitor is required in the circuit, connect a resistor in series before the capacitor. It is recommended to select a series resistance of 100 Ω or more.

15. OCD function for STK-616A-25ML5B5

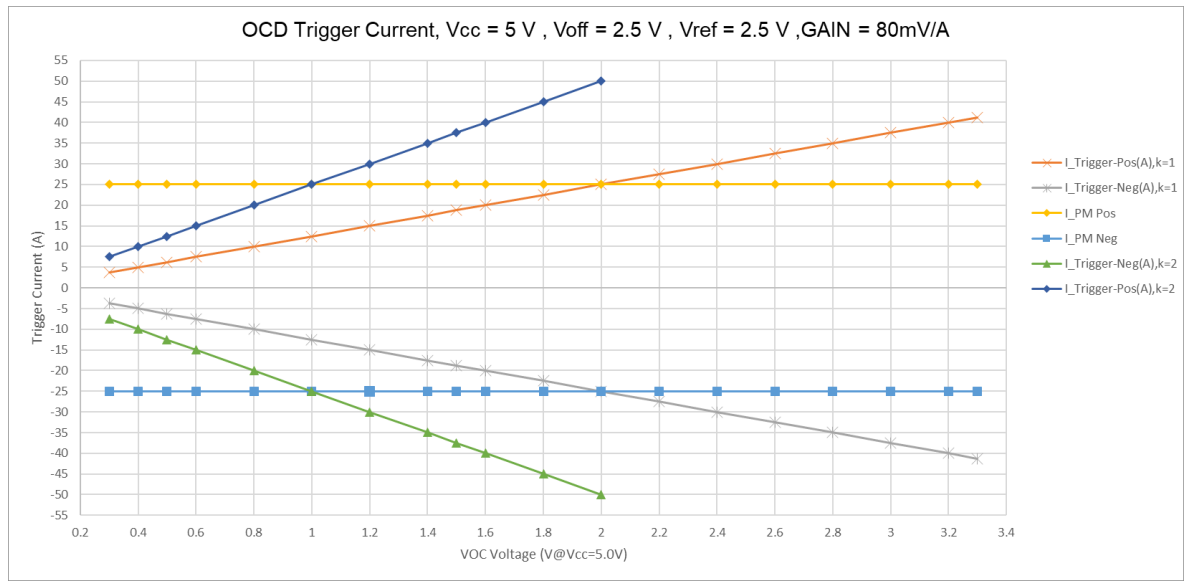

Figure 8 the relationship of trigger current and VOC setting for the STK-616A-25ML5B5, with Vcc = 5 V. I_trigger_pos represents the forward over-current protection trigger current. I_trigger_neg represents the

negative over-current protection trigger current. I_{PN_pos} represents the forward primary nominal current. I_{PN_neg} represents the negative primary nominal current. K is OCD coefficient, with typical values of 1, 2. I_{PN} is shown in the electrical data table.

16. OCD function for STK-616A-50ML5B5

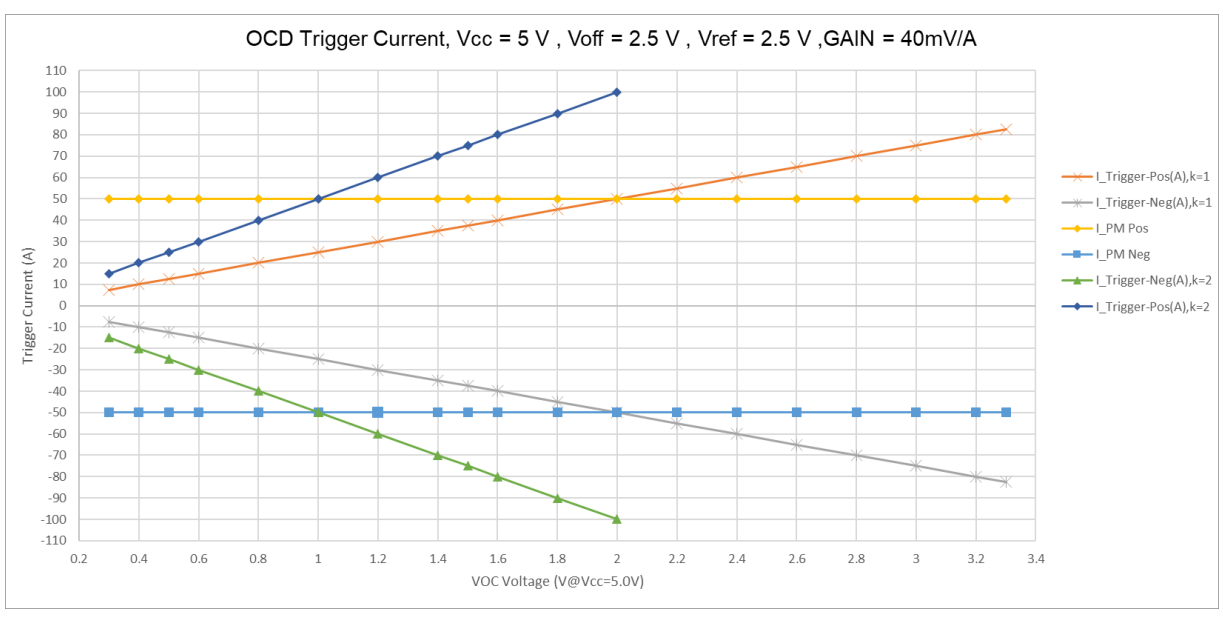

Figure 9 the relationship of trigger current and VOC setting for the STK-616A-50ML5B5, with $V_{cc} = 5V$. $I_{trigger_pos}$ represents the forward over-current protection trigger current. $I_{trigger_neg}$ represents the negative over-current protection trigger current. I_{PN_pos} represents the forward primary nominal current. I_{PN_neg} represents the negative primary nominal current. K is OCD coefficient, with typical values of 1, 2. I_{PN} is shown in the electrical data table.

17. OCD function for STK-616A-80ML5B5

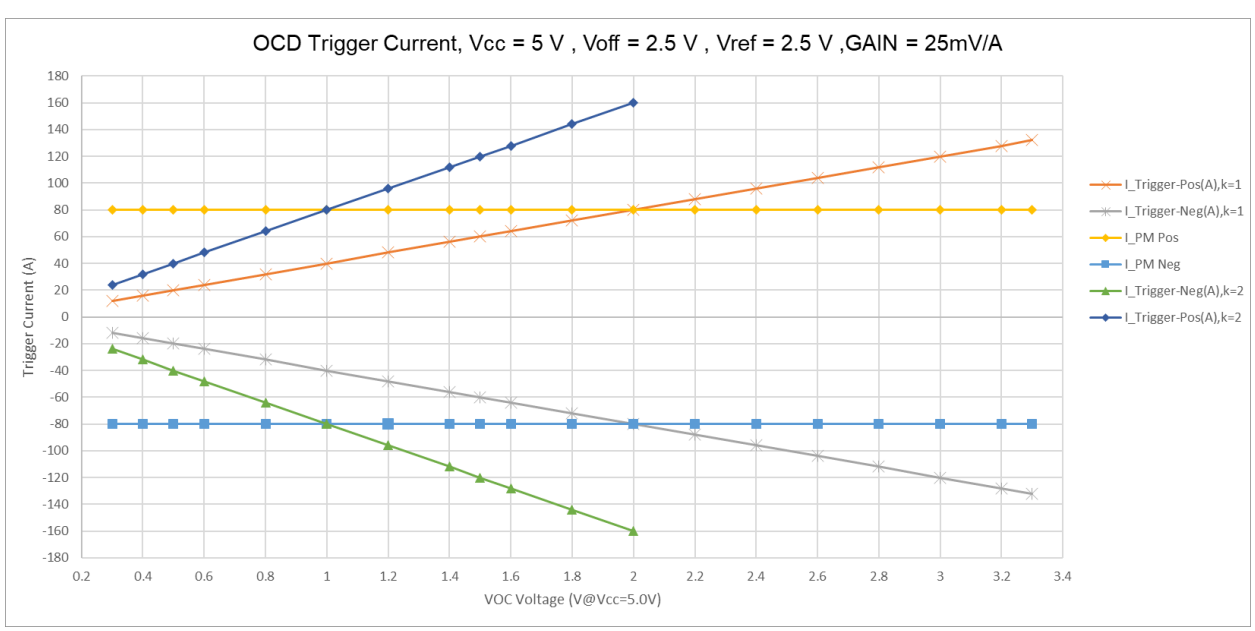

Figure 10 the relationship of trigger current and VOC setting for the STK-616A-80ML5B5, with $V_{cc} = 5\text{ V}$. $I_{\text{trigger_pos}}$ represents the forward over-current protection trigger current. $I_{\text{trigger_neg}}$ represents the negative over-current protection trigger current. $I_{\text{PN_pos}}$ represents the forward primary nominal current. $I_{\text{PN_neg}}$ represents the negative primary nominal current. K is OCD coefficient, with typical values of 1, 2. I_{PN} is shown in the electrical data table.

18. General information on OCD

This section describes the general information on OCD function, the specific functions, which are not listed in the section of “electrical data”, can be defined per request.

Since the trigger voltage is set after the second amplifier, the OCD function supports that the trigger current can be higher than I_{PN} . The trigger voltage and the trigger current are shown as follows.

- a) $V_{cc} = 5\text{ V}, V_{\text{ref}} = 2.5\text{ V}, V_{\text{off}} = 2.5\text{ V}, K=1.$
 - a) $0.3\text{ V} \leq \text{VOC} \leq 3.3\text{ V};$
 - b) $V_{\text{trigger}} = V_{\text{ref}} \pm K * \text{VOC} / G3;$
 - c) $I_{\text{trigger}} = (V_{\text{ref}} \pm K * \text{VOC} - V_{\text{off}}) / G_{\text{th}};$
- b) $V_{cc} = 5\text{ V}, V_{\text{ref}} = 2.5\text{ V}, V_{\text{off}} = 2.5\text{ V}, K=2.$
 - a) $0.3\text{ V} \leq \text{VOC} \leq 2\text{ V};$
 - b) $V_{\text{trigger}} = V_{\text{ref}} \pm K * \text{VOC} / G3;$
 - c) $I_{\text{trigger}} = (V_{\text{ref}} \pm K * \text{VOC} - V_{\text{off}}) / G_{\text{th}};$
- c) $V_{cc} = 3.3\text{ V}, V_{\text{ref}} = 1.65\text{ V}, V_{\text{off}} = 1.65\text{ V}, K=1.$
 - a) $0.3\text{ V} \leq \text{VOC} \leq 1.6\text{ V};$
 - b) $V_{\text{trigger}} = V_{\text{ref}} \pm K * \text{VOC} / G3;$
 - c) $I_{\text{trigger}} = (V_{\text{ref}} \pm K * \text{VOC} - V_{\text{off}}) / G_{\text{th}};$
- d) $V_{cc} = 3.3\text{ V}, V_{\text{ref}} = 1.65\text{ V}, V_{\text{off}} = 1.65\text{ V}, K=2.$
 - a) $0.3\text{ V} \leq \text{VOC} \leq 1.6\text{ V};$
 - b) $V_{\text{trigger}} = V_{\text{ref}} \pm K * \text{VOC} / G3;$
 - c) $I_{\text{trigger}} = (V_{\text{ref}} \pm K * \text{VOC} - V_{\text{off}}) / G_{\text{th}};$

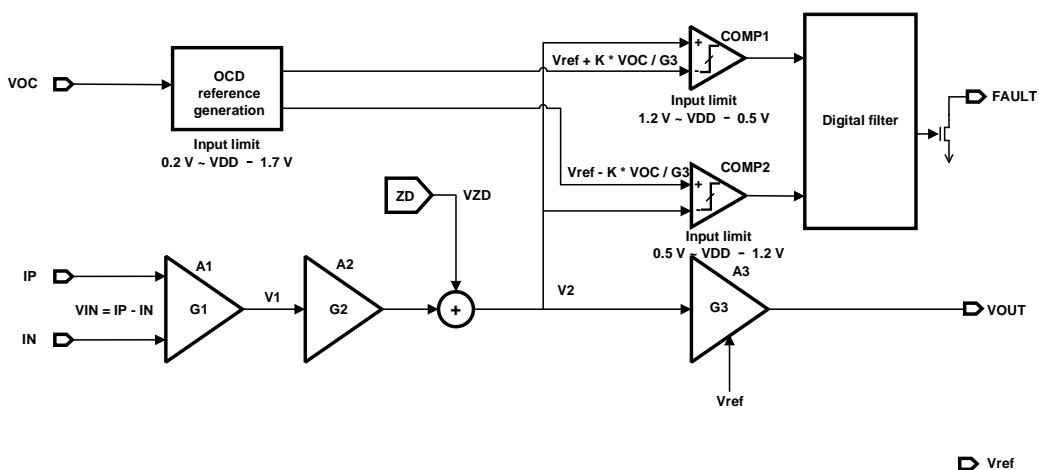

Figure 11 the functional block diagram for STK-616AM5 on OCD function with conditions of $V_{cc} = 5\text{ V}$, $V_{\text{off}} = 2.5\text{ V}$, $V_{\text{ref}} = 2.5\text{ V}$.

19. PACKAGE MATERIALS INFORMATION

TAPE AND REEL INFORMATION

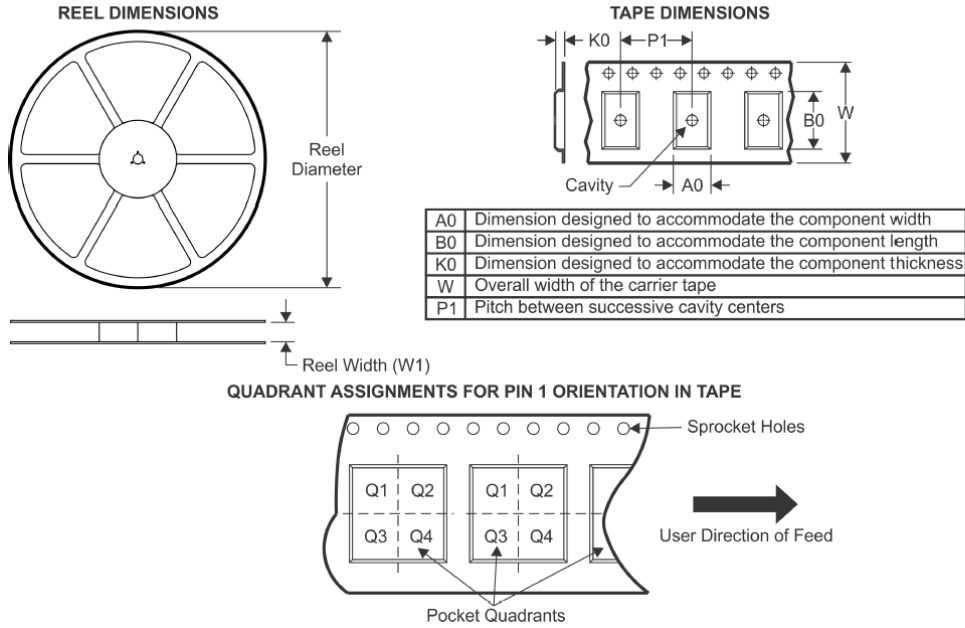

Figure 12 package materials information.