

Current Sensor

Product Series: STK-616TMF

STK-616T-10MFB5

STK-616T-20MFB5

STK-616T-40MFB5

STK-616T-50MFB5

STK-616T-65MFB5

STK-616T-75MFB5

STK-616T-10MFB3

Part number: STK-616T-20MFB3

STK-616T-30MFB3

STK-616T-40MFB3

STK-616T-50MFB3

STK-616T-65MFB3

STK-616T-66MFB3

STK-616T-100MFB3

Version: Ver 3.7

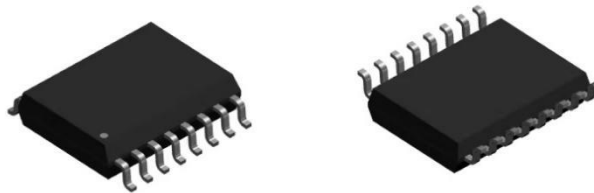

Sinomags Technology Co., Ltd

Web site: www.sinomags.com

CONTENT

1.	Description	2
2.	Part number definition	3
3.	Temperature vs Current.....	4
4.	Functional Block Diagram.....	4
5.	Electrical data STK-616T-XXMFB5.....	5
6.	Electrical data STK-616T-XXMFB3.....	6
7.	Dimension & Pin definitions with OCD function	7
8.	Pin definitions	8
9.	PCB layout recommendation	8
10.	Frequency bandwidth of STK-616T-XXMFBX.....	9
11.	Step response time of STK-616T-XXMFBX	9
12.	Typical Application of STK-616TMF	10
13.	Examples of OCD function	11
14.	General information on OCD.....	12
15.	PACKAGE MATERIALS INFORMATION	13

1. Description

The STK-616TM series current sensor is based on TMR (tunnel magneto resistance) technology and open-loop design. It is suitable for DC, AC pulsed and any kind of irregular current measurement under the isolated conditions.

- The product is packaged in standard SOIC16 form.
- AEC-Q100, automotive qualified.

Typical applications

- AC Variable speed drives
- AC/DC, DC/DC power supplies
- Inverter
- Switched model power supplies (SMPS)

General parameter

Parameter	Symbol	Unit	Value
Working temperature	T_A	°C	-40 ~ 125
Storage temperature	T_stg	°C	-40 ~ 125
Mass	m	g	0.5

Absolute maximum rating

Parameter	Symbol	Unit	Value
Supply voltage	V _{cc}	V	6
ESD rating (HBM)	U_ESD	kV	4
Junction temperature	T _J	°C	150

Remark: the unrecoverable damage may occur when the product works on the conditions over the absolute maximum ratings. Long-time working on the absolute maximum ratings may cause the degradation on performance and reliability.

Isolation parameter

Parameter	Symbol	Unit	Value	Comment
RMS voltage for AC test 50Hz/1 min	U _d	kV	3.6	
Impulse withstand voltage 1.2/50μs	Ū _w	kV	6	
Clearance distance (pri. -sec)	D _{ci}	mm	8	Determined by customer's layout
Creepage distance (pri. -sec)	D _{cp}	mm	8	

Measuring current table

Product	Meas. Range I _{pn} (A)	Sensitivity (mV/A)	V _{cc} (V)	T (°C)
STK-616T-10MFB3-1-1.65-E-2-C-N	±10A	132	3.3	-40 ~ 125
STK-616T-20MFB3-1-1.65-E-2-C-N	±20A	66	3.3	-40 ~ 125
STK-616T-30MFB3-1-1.65-E-0-Z-R	±30A	44	3.3	-40 ~ 125
STK-616T-40MFB3-1-1.65-E-2-C-N	±40A	33	3.3	-40 ~ 125
STK-616T-40MFB3-1-1.65-E-0-Z-R	±40A	33	3.3	-40 ~ 125
STK-616T-50MFB3-1-1.65-E-2-C-N	±50A	26.4	3.3	-40 ~ 125
STK-616T-65MFB3-1-1.65-E-2-C-N	±65A	20.3	3.3	-40 ~ 125

STK-616T-65MFB3-1-1.65-E-0-Z-R-2	±65A	20.3	3.3	-40 ~ 125
STK-616T-66MFB3-1-1.65-E-1-Z-R	±66A	20	3.3	-40 ~ 125
STK-616T-100MFB3-0-1.65-X-X-X-R	±100A	13.2	3.3	-40 ~ 125
STK-616T-10MFB5-0-2.5-X-X-X-N	±10A	200	5	-40 ~ 125
STK-616T-20MFB5-1-2.5-E-2-C-N	±20A	100	5	-40 ~ 125
STK-616T-40MFB5-1-2.5-E-2-C-N	±40A	50	5	-40 ~ 125
STK-616T-50MFB5-1-2.5-E-2-C-N	±50A	40	5	-40 ~ 125
STK-616T-65MFB5-1-2.5-E-2-C-N	±65A	30.8	5	-40 ~ 125
STK-616T-75MFB5-1-2.5-E-2-C-R-2	±75A	26.7	5	-40 ~ 125

2. Part number definition

STK - 616T - 40MF - B - 5 - 1 - 2.5 - E - 2 - C - N - K

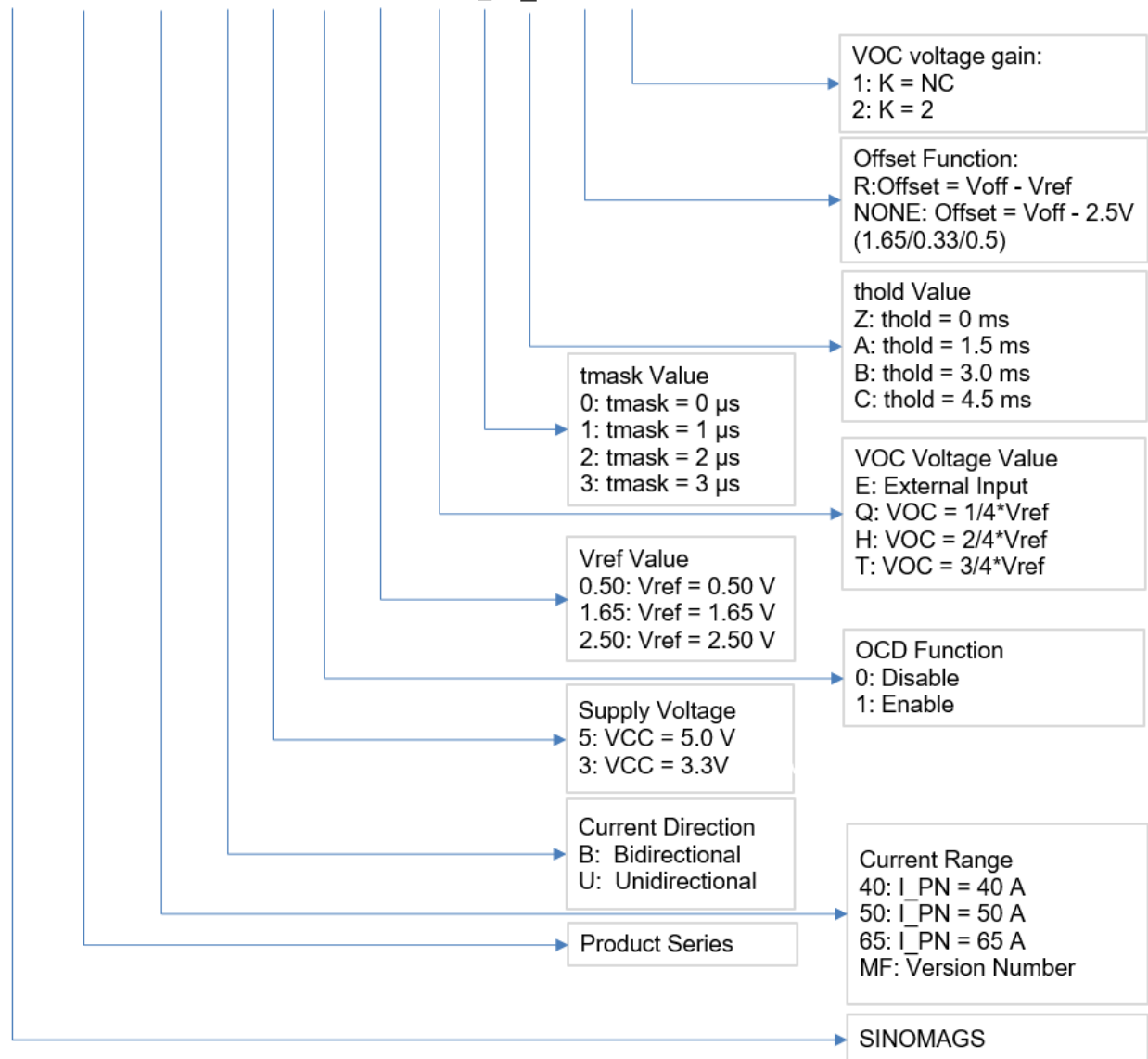

3. Temperature vs Current

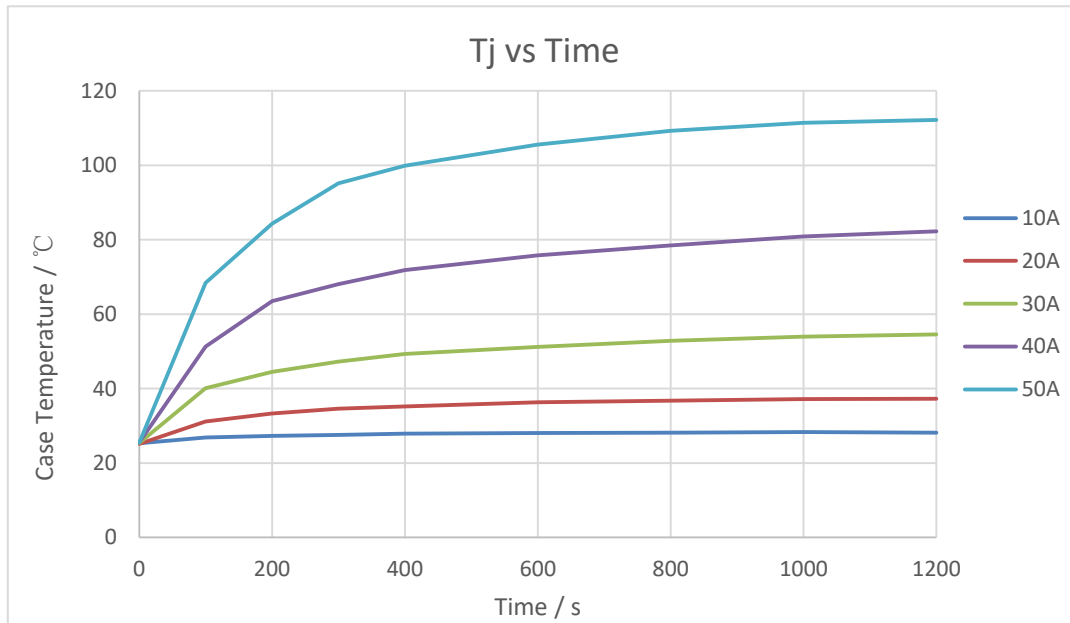

Figure 1. Relationship between STK-616TM Case temperature and amount of input current

Remark 1: Figure 1 shows the results of current & temperature measurement. Tested by using a standard demo test board, with 4 layers of copper conductors, where the thickness for each layer is 2 oz, the total thickness of demo board is 1.6 mm. This result is a reference data. Tc is changed much by the board layout and the heat dissipation. Please confirm it in your evaluation environment.

4. Functional Block Diagram

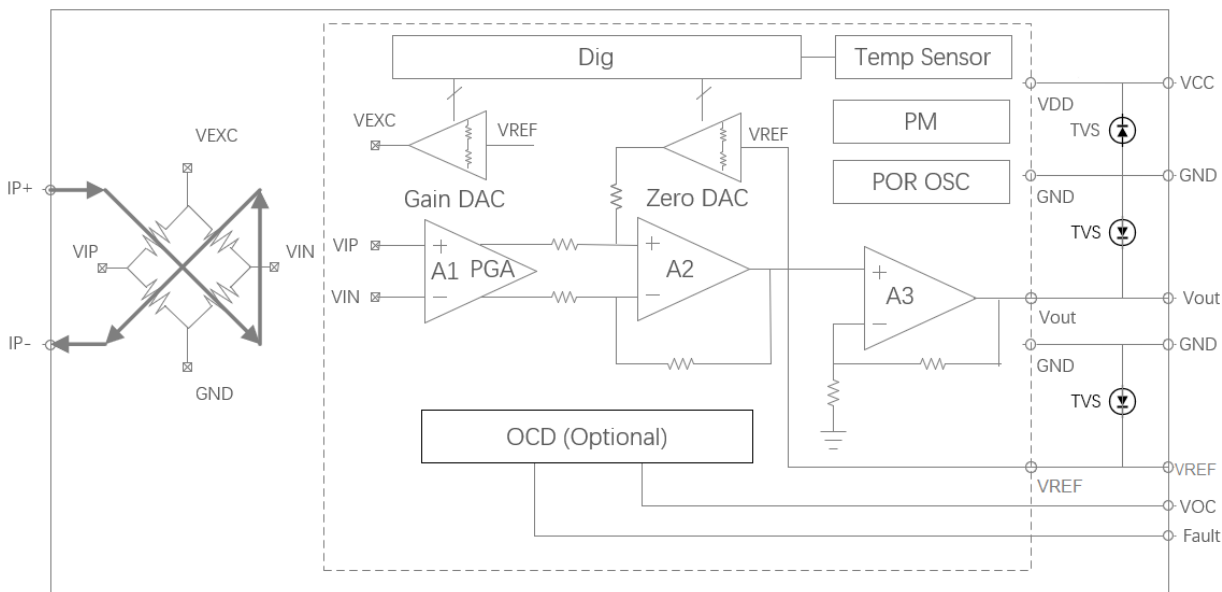

Figure 2 the functional block diagram for the STK-616TM series products.

Remark 2: A1, A2 and A3 represent the operational amplifiers of the current sensor.

5. Electrical data STK-616T-XXMFB5

Condition: $T_A = 25^{\circ}\text{C}$, $V_{CC} = 5\text{V}$

Parameter	Symbol	Unit	Min	Typ	Max	Comment
General parameters						
Primary nominal current	I_{pn}	A	-10		10	STK-616T-10MFB5
			-20		20	STK-616T-20MFB5
			-40		40	STK-616T-40MFB5
			-50		50	STK-616T-50MFB5
			-65		65	STK-616T-65MFB5
			-75		75	STK-616T-75MFB5
Supply voltage	V_{CC}	V	4.5	5	5.5	
Current consumption	I_{CC}	mA		7	12	
Primary conductor resistance	R_{IP}	m Ω		0.85		
Quiescent voltage@0A	V_{off}	V	2.45	2.5	2.55	
Reference voltage	V_{ref}	V	2.45	2.5	2.55	
Electrical offset voltage	Offset	mV		± 10		$V_{off} - V_{ref}$
Output Specifications	R_{out}	Ω	1		30	
	R_{ref}		1		80	
Theoretical gain	G_{th}	mV/A		200		STK-616T-10MFB5
				100		STK-616T-20MFB5
				50		STK-616T-40MFB5
				40		STK-616T-50MFB5
				30.8		STK-616T-65MFB5
				26.7		STK-616T-75MFB5
OCD function (if applicable)						
OCD range	VOC	V	0.3		3.3	K=1
			0.3		2	K=2
FAULT error		%		5%		% of OCD
OCD	IHYS	%		10%		% of OCD
OCD Fault Mask	tmask	μs		2		0, 1, 2, 3 μs
OCD Fault Mask error	Tmask_error	ns		125		
OCD Fault Hold Time	thold	ms		4.5		0, 1.5, 3, 4.5 ms
Accuracy performance						
Rated linearity error@25 $^{\circ}\text{C}$	Non-L	% I_{pn}		± 1.5		$\pm I_{pn}$
Step response time	t_res	μs		0.2		@90% of I_{pn} STK-616T-XXMFBX
Frequency bandwidth	BW	MHz		1.5		@-3dB STK-616T-XXMFBX
Output voltage noise	Vnoise	mVpp		10		@1.4 MHz

Thermal drift of G _{th}	GAIN_T	% G _{th}		±1.5		@ -40~105°C drift related to the value @25°C
Thermal drift of V _{off}	Voff_T	mV		±15		
Total Accuracy	X_TRange	% I _{pn}		±3.5		

6. Electrical data STK-616T-XXMFB3

Condition: T_A = 25°C, V_{cc} = 3.3 V

Parameter	Symbol	Unit	Min	Typ	Max	Comment
General parameters						
Primary nominal current	I _{pn}	A	-10		10	STK-616T-10MFB3
			-20		20	STK-616T-20MFB3
			-30		30	STK-616T-30MFB3
			-40		40	STK-616T-40MFB3
			-50		50	STK-616T-50MFB3
			-65		65	STK-616T-65MFB3
			-66		66	STK-616T-66MFB3
			-100		100	STK-616T-100MFB3
Supply voltage	V _{cc}	V	3.15	3.3	3.45	
Current consumption	I _{cc}	mA		7	12	
Primary conductor resistance	R _{IP}	mΩ		0.9		
Quiescent voltage@0A	V _{off}	V	1.6	1.65	1.7	
Reference voltage	V _{ref}	V	1.6	1.65	1.7	
Electrical offset voltage	Offset	mV		±10		V _{off} - V _{ref}
Output Specifications	R _{out}	Ω	1		30	
	R _{ref}		1		80	
Theoretical gain	G _{th}	mV/A		132		STK-616T-10MFB3
				66		STK-616T-20MFB3
				44		STK-616T-30MFB3
				33		STK-616T-40MFB3
				26.4		STK-616T-50MFB3
				20.3		STK-616T-65MFB3
				20		STK-616T-66MFB3
				13.2		STK-616T-100MFB3
OCD function (if applicable)						
OCD range	VOC	V	0.3		1.6	K=1
			0.3		1.6	K=2
FAULT error		%		5%		% of OCD
OCD Hysteresis	I _{HYS}	%		10%		% of OCD
OCD Fault Mask	t _{mask}	μs		2		0, 1, 2, 3 μs
OCD Fault Mask error	T _{mask_error}	ns		125		
OCD Fault Hold Time	t _{hold}	ms		4.5		0, 1.5, 3, 4.5 ms
Accuracy performance						

Rated error@25°C	linearity	Non-L	%I _{pn}		±1.5		±I _{pn}
Step response time	t _{res}		μs		0.2		@90% of I _{pn} STK-616T-XXMFBX
Frequency bandwidth	BW		MHz		1.5		@-3dB STK-616T-XXMFBX
Output voltage noise	Vnoise		mVpp		10		@1.4 MHz
Thermal drift of G _{th}	GAIN_T		% G _{th}		±1.5		@ -40~105°C drift related to the value @25°C
Thermal drift of Voff	Voff_T		mV		±15		
Total Accuracy	X_TRange		% I _{pn}		±3.5		

7. Dimension & Pin definitions with OCD function

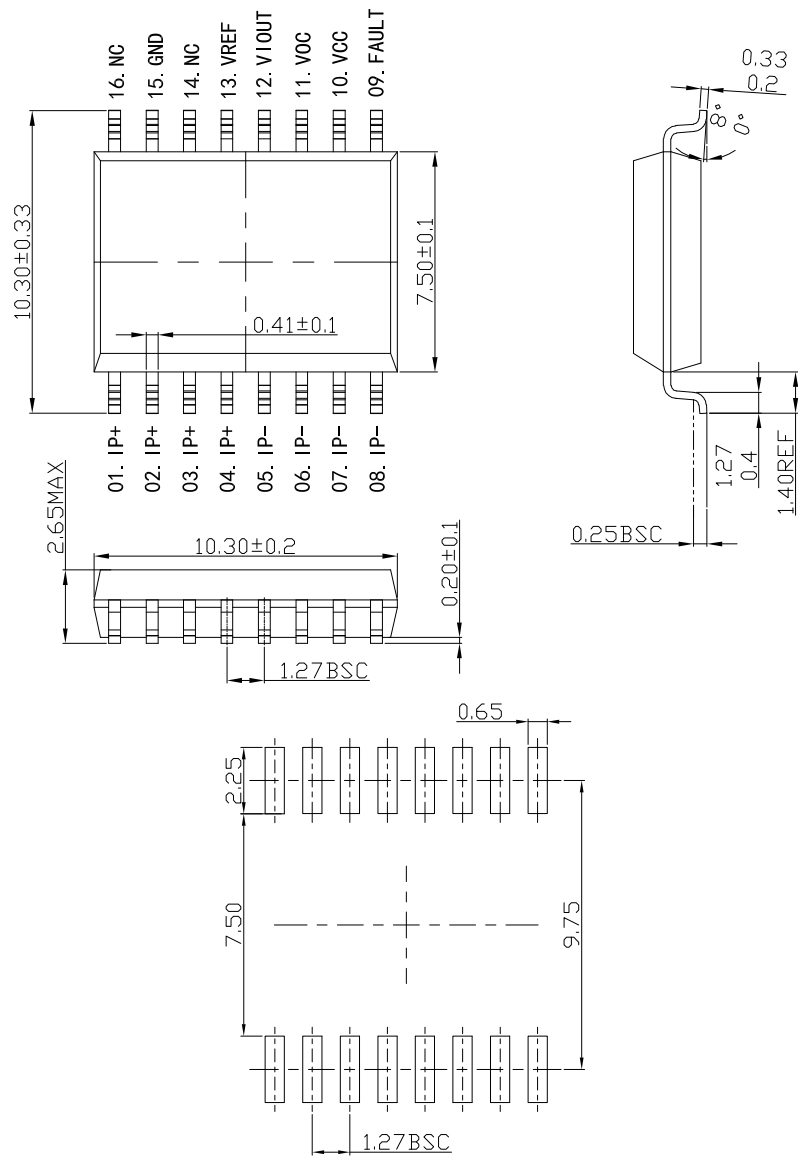

PCB Layout Reference View

Figure 3 dimensions of STK-616TM series current sensors. The unit is mm.

8. Pin definitions

Pin definition for product with OCD function

PIN	Symbol	Description
1,2,3,4	IP+	Primary conductor pin (+)
5,6,7,8	IP-	Primary conductor pin (-)
9	FAULT	Over current detection alarm output, the pin is open leakage output. Normally, the output of fault pin is high level.
10	VCC	Power supply pin
11	VOC	Over current detection threshold input pin
12	VIOUT	Sensor output pin
13	VREF	Reference pin, output function
14	NC	No connection
15	GND	Ground pin (GND)
16	NC	No connection

9. PCB layout recommendation

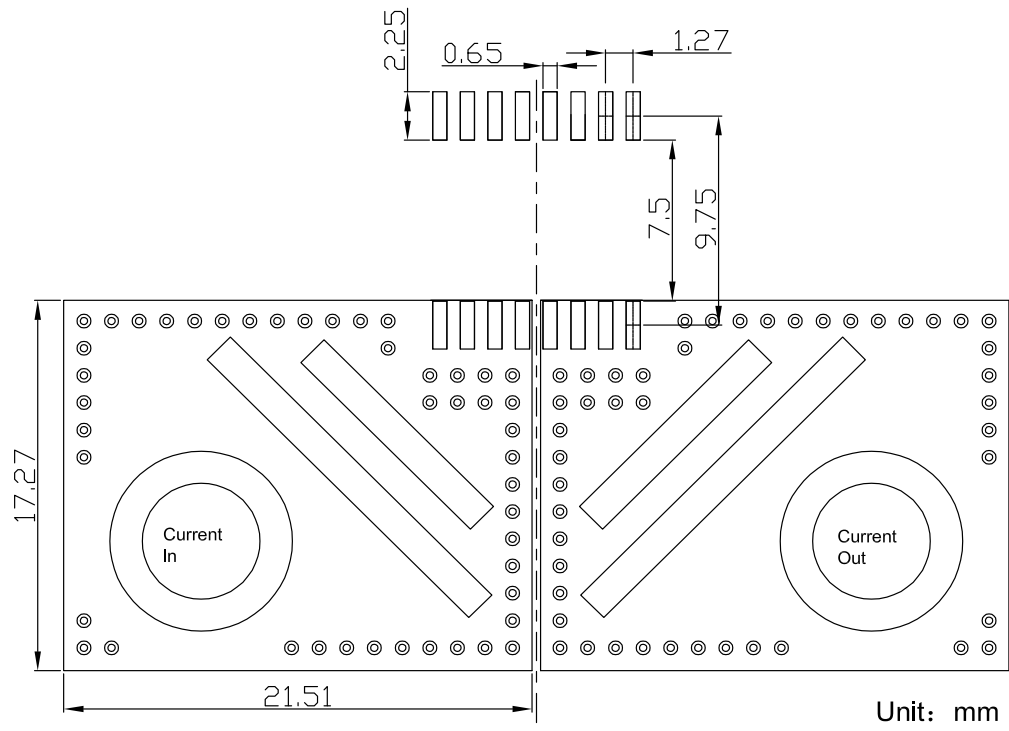

Figure 4 the recommended footprint of the SMT PCB layout for the STK-616TM series products. The unit is mm.

10. Frequency bandwidth of STK-616T-XXMFBX

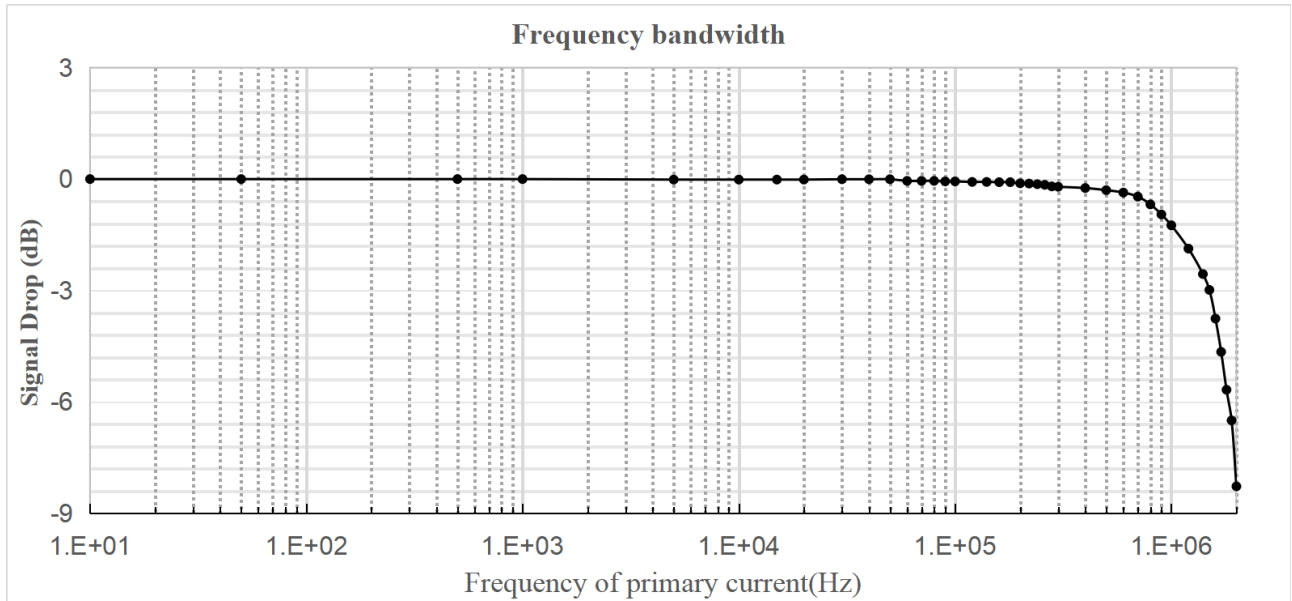

Figure 5 the frequency band width of the STK-616TM series products. the upper limit of the -3 dB band width is 1.5 MHz.

11. Step response time of STK-616T-XXMFBX

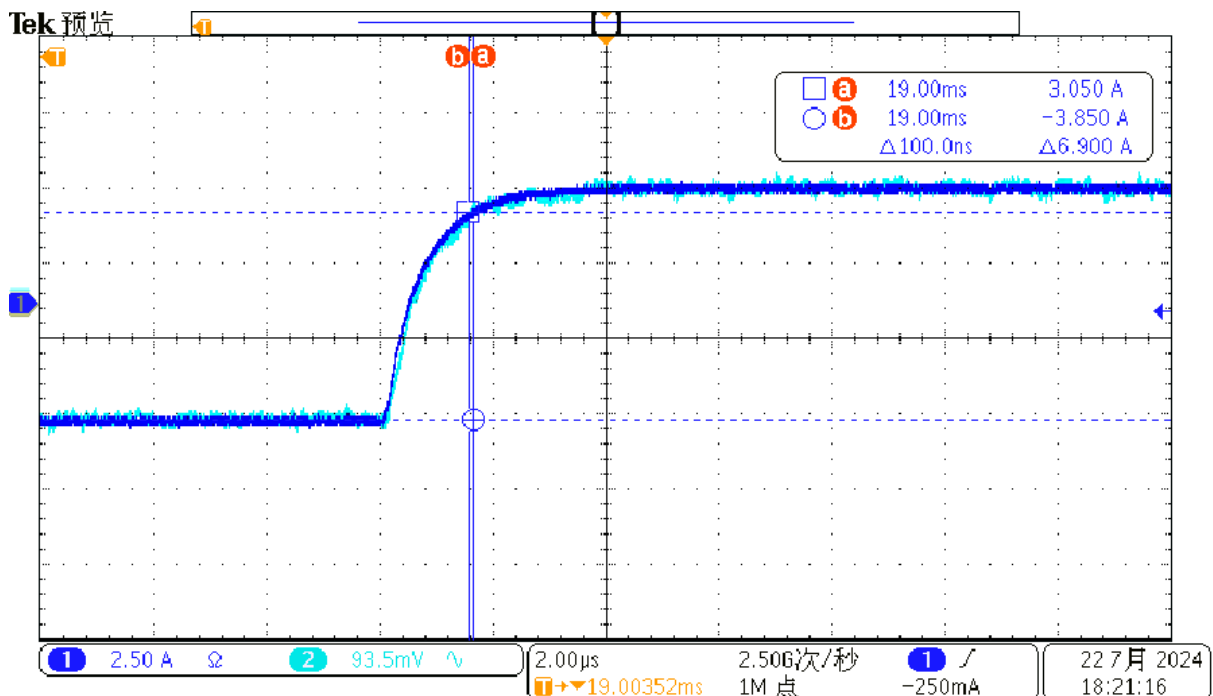

Figure 6 the typical high frequency response of STK-616TM current sensor. The response time from 90% of the primary current to 90% of the secondary output is 0.2μs.

12. Typical Application of STK-616TMF

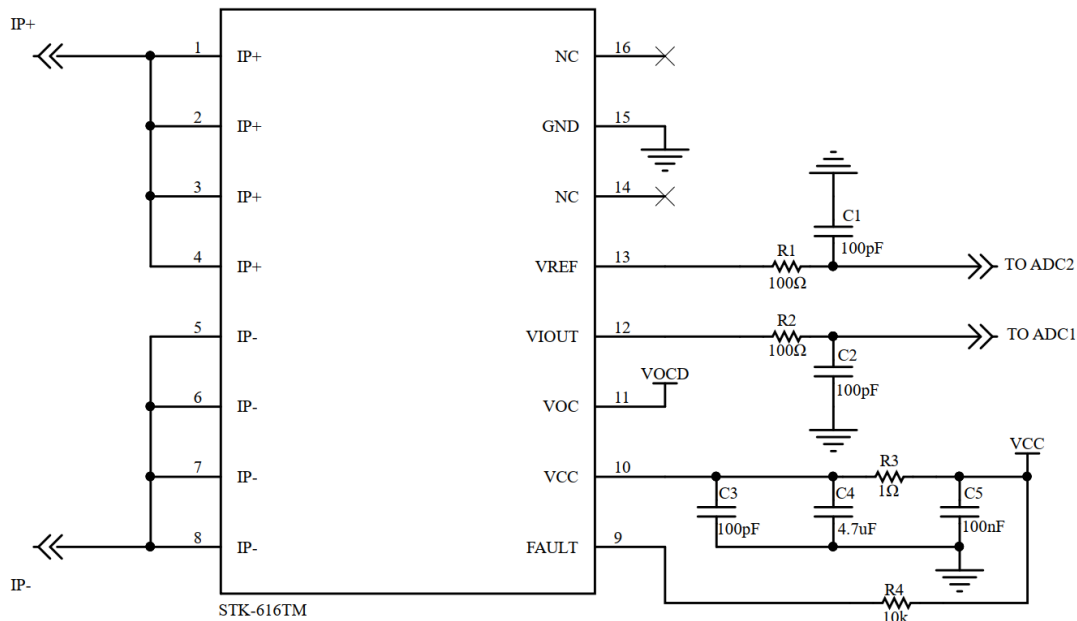

Figure 7 the reference application circuit for the STK-616TM series products.

Remark 3: R4 = 10 kΩ, recommended C1 = 100 pF, C2 = 100 pF, C3 = 100 pF, C4 = 4.7 μF, C5 = 100 nF. 100 pF of C1 and C2 does not affect the response speed of the chip. R1 and C1 constitute RC filter circuit ($f \approx 1 / (2\pi RC)$). The bandwidth of the STK-616TMF is 1.5 MHz, and RC filter circuit above 1.5 MHz cannot realize a bandwidth above 1.5 MHz. If the VREF pin is not used, it can be left empty. If there is a need for an external capacitor, it is necessary to ensure that the capacitance value is greater than 100nF.

Remark 4: The VREF and VOUT pins cannot be connected directly to a capacitor. if a capacitor is required in the circuit, connect a resistor in series before the capacitor. It is recommended to select a series resistance of 100 Ω or more.

13.Examples of OCD function

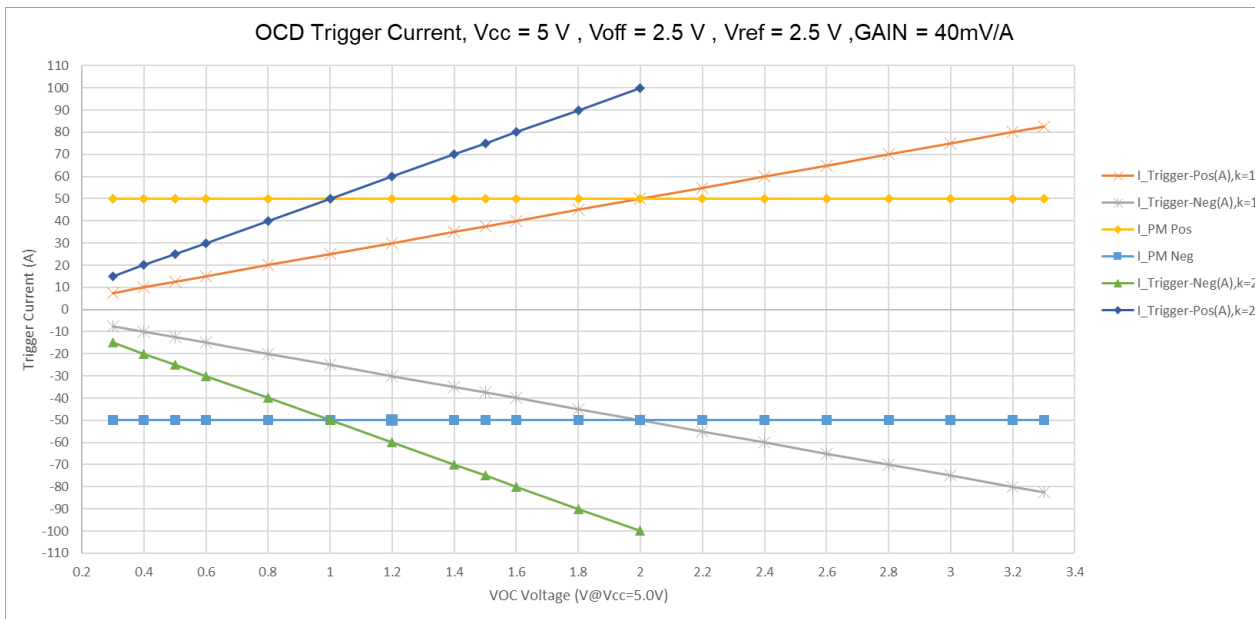
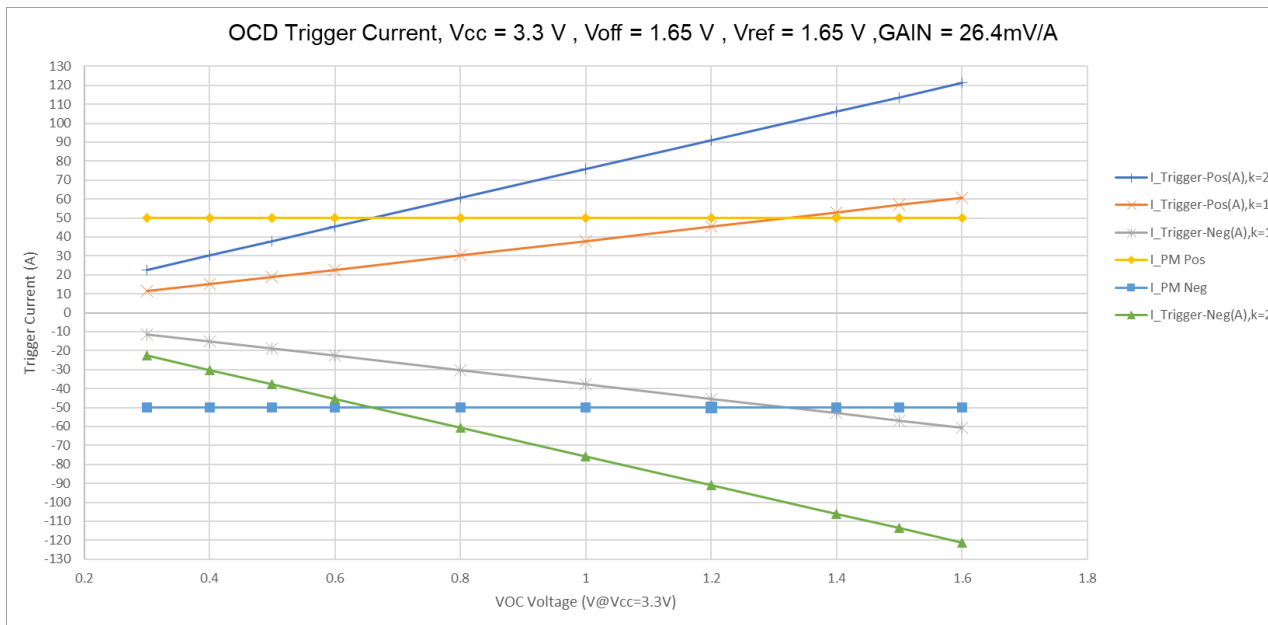

Figure 8 the relationship of trigger current and VOC setting for the STK-616T-50MFB5, with $V_{cc} = 5\text{ V}$. $I_{trigger_pos}$ represents the forward over-current protection trigger current. $I_{trigger_neg}$ represents the negative over-current protection trigger current. I_{PN_pos} represents the forward primary nominal current. I_{PN_neg} represents the negative primary nominal current. K is OCD coefficient, with typical



values of 1, 2. I_{PN} is shown in the electrical data table.

Figure 9 the relationship of trigger current and VOC setting for the STK-616T-50MFB3, with $V_{cc} = 3.3\text{ V}$. $I_{trigger_pos}$ represents the forward over-current protection trigger current. $I_{trigger_neg}$ represents the negative over-current protection trigger current. I_{PN_pos} represents the forward primary nominal current. I_{PN_neg} represents the negative primary nominal current. K is OCD coefficient, with typical values of 1, 2. I_{PN} is shown in the electrical data table.

14. General information on OCD

This section describes the general information on OCD function, the specific functions, which are not listed in the section of “electrical data”, can be defined per request.

Since the trigger voltage is set after the second amplifier, the OCD function supports that the trigger current can be higher than I_{pn} . The trigger voltage can be defined:

- a) $V_{ref} = 2.5\text{ V}, K=1$
 - ①. $0.3\text{ V} \cong V_{OC} \cong 3.3\text{ V};$
 - ②. Trigger voltage = $V_{ref} \pm V_{OC};$
 - ③. Trigger current = $(V_{ref} \pm V_{OC} - V_{off}) / G_{th};$
- b) $V_{ref} = 1.65\text{ V}, K=1$
 - ①. $0.3\text{ V} \cong V_{OC} \cong 1.6\text{ V};$
 - ②. Trigger voltage = $V_{ref} \pm V_{OC};$
 - ③. Trigger current = $(V_{ref} \pm V_{OC} - V_{off}) / G_{th};$
- c) $V_{ref} = 0.5\text{ V}, K=1$
 - ①. $0.2\text{ V} \cong V_{OC} \cong 0.5\text{ V};$
 - ②. Trigger voltage = $V_{ref} + 8 \cdot V_{OC};$
 - ③. Trigger current = $(V_{ref} + V_{OC} - V_{off}) / G_{th};$
- d) $V_{ref} = 2.5\text{ V}, K=2$
 - ①. $0.5\text{ V} \cong V_{OC} \cong 2\text{ V};$
 - ②. Trigger voltage = $V_{ref} \pm K \cdot V_{OC};$
 - ③. Trigger current = $(V_{ref} \pm K \cdot V_{OC} - V_{off}) / G_{th};$
- e) $V_{ref} = 1.65\text{ V}, K=2$
 - ①. $0.3\text{ V} \cong V_{OC} \cong 1.6\text{ V};$
 - ②. Trigger voltage = $V_{ref} \pm K \cdot V_{OC};$
 - ③. Trigger current = $(V_{ref} \pm K \cdot V_{OC} - V_{off}) / G_{th};$
- f) $V_{ref} = 0.5\text{ V}, K=2$
 - ①. $0.2\text{ V} \cong V_{OC} \cong 0.5\text{ V};$
 - ②. Trigger voltage = $V_{ref} + 8 \cdot V_{OC};$
 - ③. Trigger current = $(V_{ref} + 8 \cdot V_{OC} - V_{off}) / G_{th};$

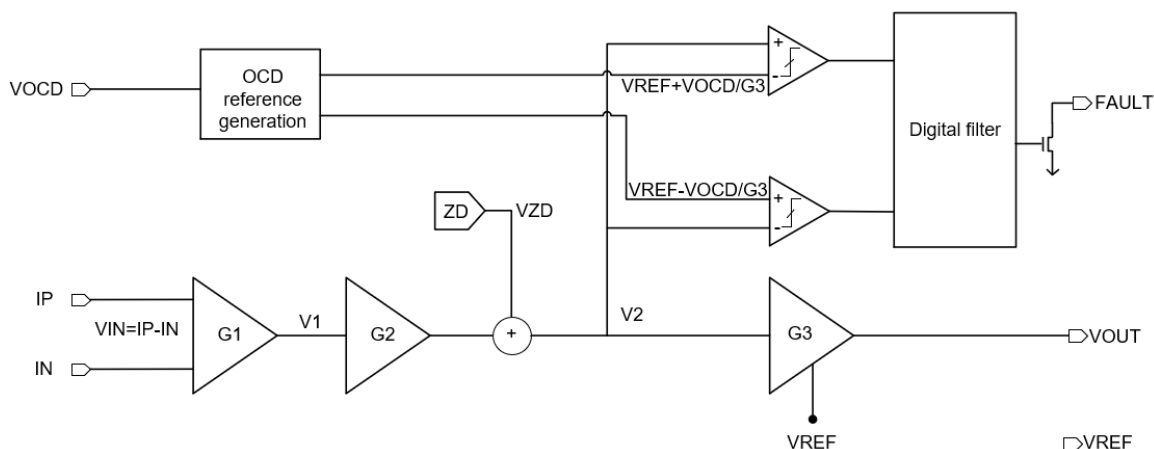

Figure 10 the functional block diagram for STK-616TM on OCD function with conditions of $V_{cc} = 5\text{ V}$, $V_{off} = 2.5\text{ V}$, $V_{ref} = 2.5\text{ V}$.

15. PACKAGE MATERIALS INFORMATION

TAPE AND REEL INFORMATION

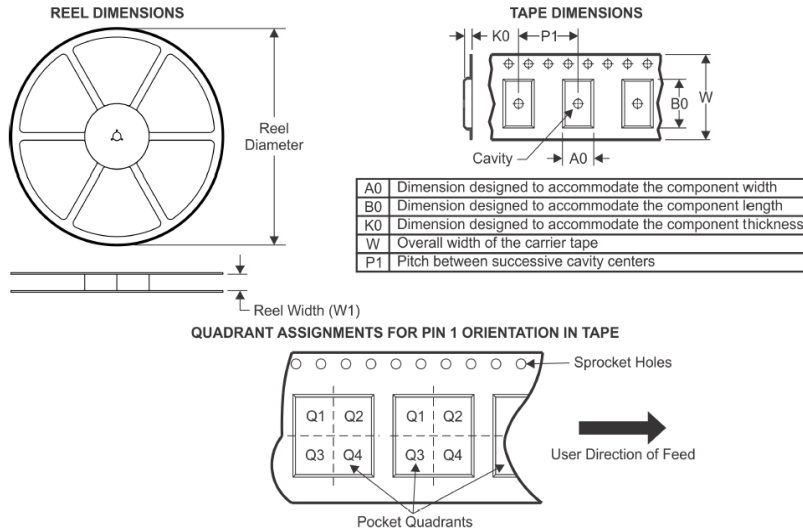

Figure 11 package materials information.