

Current Sensor

Product Series: STK-616ZMF

Part number:

STK-616Z-10MFU5
STK-616Z-10MFB5
STK-616Z-10MFB3
STK-616Z-20MFB5
STK-616Z-20MFB3
STK-616Z-25MFB3
STK-616Z-25MFB5
STK-616Z-30MFB5
STK-616Z-30MFB3
STK-616Z-30MFU5
STK-616Z-30MFU3
STK-616Z-40MFB5
STK-616Z-40MFB3
STK-616Z-50MFB5
STK-616Z-50MFB3
STK-616Z-50MFU3
STK-616Z-50MFU5
STK-616Z-65MFB5
STK-616Z-65MFB3

Version: Ver 3.6

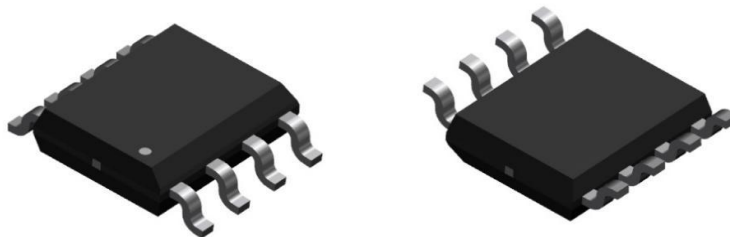

Sinomags Technology Co., Ltd

Web site: www.sinomags.com

CONTENT

1.	Introduction	2
2.	Package: SOIC8 compatible	3
3.	Selection Guide	4
4.	Production Information	5
5.	Electrical data STK-616Z-XXMFB5.....	6
6.	Electrical data STK-616Z-XXMFU5	7
7.	Electrical data STK-616Z-XXMFB3.....	7
8.	Electrical data STK-616Z-XXMFU3	8
9.	Typical Application Circuit.....	8
10.	Characteristic Definitions	9
11.	Continues current vs working temperature	9
12.	Dimension & Pin Definitions	10
13.	Pin definitions	11
14.	Frequency bandwidth of STK-616Z-XXMFBX.....	11
15.	Step response time of STK-616Z-XXMFBX	11
16.	The delay time of the Triangular wave.....	12
17.	Package materials information.....	13

1. Introduction

STK-616ZM series current sensor is based on TMR (tunnel magneto resistance) technology, and it has an open-loop design. It is suitable for DC, AC pulsed and any kind of irregular current measurement under the isolated conditions.

- The product is packaged in standard SOIC8 form.
- AEC-Q100, automotive qualified.

Typical applications

- AC variable speed drives
- Switching power supply
- Motor control

General parameter

Parameter	Symbol	Unit	Value
Working temperature	T_A	°C	-40 ~ 125
Storage temperature	T_stg	°C	-40 ~ 125
Mass	m	g	0.1

Absolute maximum rating

Parameter	Symbol	Unit	Value
Supply voltage	V _{CC}	V	6
ESD rating (HBM)	U _{ESD}	kV	2

Remark: the unrecoverable damage may occur when the product works on the conditions over the absolute maximum ratings. Long-time working on the absolute maximum ratings may cause the degradation on performance and reliability.

Isolation parameter

Parameter	Symbol	Unit	Value	Comment
RMS voltage for AC test 50Hz/1 min	U _d	kV	3.6	All
Clearance distance (Shortest distance through air)	d _{Cl}	mm	4.2	All
Creepage distance (Shortest path along device body)	d _{Cp}	mm	4.2	All
Surge voltage	V _{surge}	kV	6	
Comparative tracking index	CTI	V	600	
Working voltage for basic isolation	V _{WVBI}	V _{rms}	460	
		V _{dc}	650	

2. Package: SOIC8 compatible

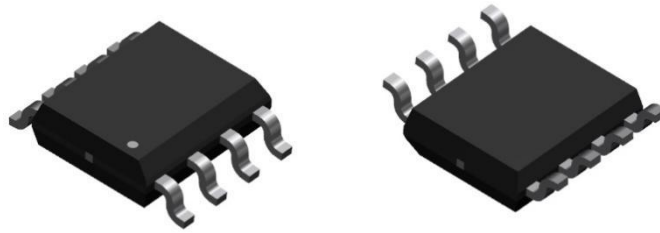

3. Selection Guide

Part Number	Vcc(V)	Current Range (A)	Sensitivity (mV/A)	Offset (V)	Current Directionality	Top(°C)
STK-616Z-10MFB5	5	±10	200	2.5	Bidirectional	-40~125
STK-616Z-20MFB5	5	±20	100	2.5	Bidirectional	-40~125
STK-616Z-25MFB5	5	±25	80	2.5	Bidirectional	-40~125
STK-616Z-30MFB5	5	±30	66.7	2.5	Bidirectional	-40~125
STK-616Z-40MFB5	5	±40	50	2.5	Bidirectional	-40~125
STK-616Z-50MFB5	5	±50	40	2.5	Bidirectional	-40~125
STK-616Z-65MFB5	5	±65	30	2.5	Bidirectional	-40~125
STK-616Z-10MFU5	5	10	400	0.5	Unidirectional	-40~125
STK-616Z-30MFU5	5	30	133.3	0.5	Unidirectional	-40~125
STK-616Z-50MFU5	5	50	80	0.5	Unidirectional	-40~125
STK-616Z-10MFB3	3.3	±10	132	1.65	Bidirectional	-40~125
STK-616Z-20MFB3	3.3	±20	66	1.65	Bidirectional	-40~125
STK-616Z-25MFB3	3.3	±25	52.8	1.65	Bidirectional	-40~125
STK-616Z-30MFB3	3.3	±30	44	1.65	Bidirectional	-40~125
STK-616Z-40MFB3	3.3	±40	33	1.65	Bidirectional	-40~125
STK-616Z-50MFB3	3.3	±50	26.4	1.65	Bidirectional	-40~125
STK-616Z-65MFB3	3.3	±65	20.3	1.65	Bidirectional	-40~125
STK-616Z-30MFU3	3.3	30	88	0.5	Unidirectional	-40~125
STK-616Z-50MFU3	3.3	50	52.8	0.5	Unidirectional	-40~125

4. Production Information

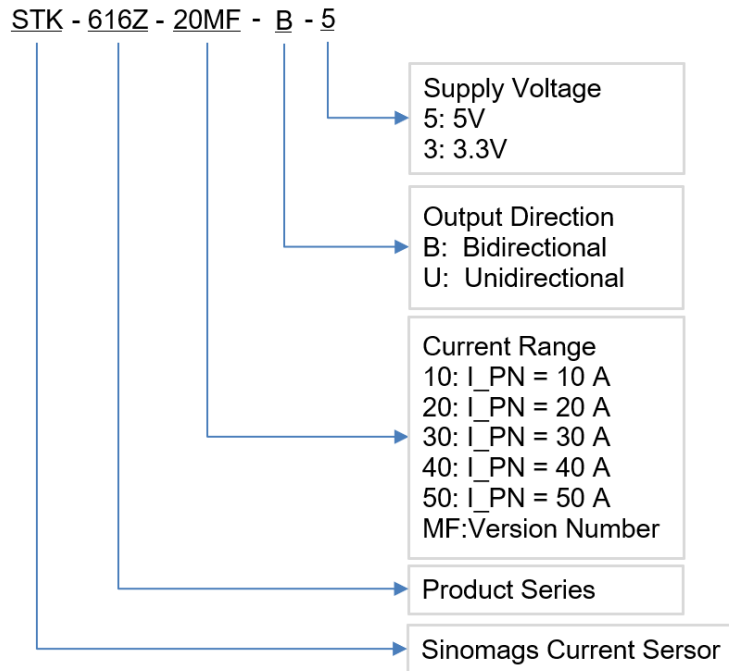

5. Electrical data STK-616Z-XXMFB5

 Condition: $T_A = 25^\circ\text{C}$, $V_{CC} = 5\text{ V}$

Parameter	Symbol	Unit	Min	Typ	Max	Comment
Supply voltage	V_{CC}	V		5±5%		STK-616Z-XXMFB5
Current consumption	I_{CC}	mA		6		STK-616Z-XXMFB5
Primary conductor resistance	R_{pr}	mΩ		0.9		STK-616Z-XXMFB5
Quiescent voltage Vout @ 0 A	$V_{IOUT(Q)}$	V		2.5±0.05		STK-616Z-XXMFB5
Zero Current Reference Voltage	V_{REF}	V		2.5±0.05		STK-616Z-XXMFB5
Peak output voltage (Vout @ ±I _{pn}) - $V_{IOUT(Q)}$	V_{FS}	V		±2		STK-616Z-XXMFB5
Internal output resistance	R_{out}	Ω		2		STK-616Z-XXMFB5
Rated linearity error	E_{LIN}	% I _{PN}		±1.5		±I _{PN}
Step response time	t_{res}	μs		0.05		@90% of I _{pn} STK-616Z-XXMFB5
Frequency bandwidth (-3dB)	BW	MHz		2		@-3dB STK-616Z-XXMFB5
Output voltage noise	V_{noise}	mVpp		10		@1.4 MHz
Accuracy @ 25°C	E_{TOT}	% of I _{PN}		±1.5		All
Accuracy @ -40°C ~ 105°C	E_{TOT}	% of I _{PN}		±3.5		All

6. Electrical data STK-616Z-XXMFU5

 Condition: $T_A = 25^{\circ}\text{C}$, $V_{CC} = 5\text{ V}$

Parameter	Symbol	Unit	Min	Typ	Max	Comment
Supply voltage	V_{CC}	V		5±5%		STK-616Z-XXMFU5
Current consumption	I_{CC}	mA		6		STK-616Z-XXMFU5
Primary conductor resistance	R_{pr}	mΩ		0.9		STK-616Z-XXMFU5
Quiescent voltage Vout @ 0 A	$V_{IOUT(Q)}$	V		0.5±0.05		STK-616Z-XXMFU5
Zero Current Reference Voltage	V_{REF}	V		0.5±0.05		STK-616Z-XXMFU5
Peak output voltage (Vout @ $+I_{pm}$) - $V_{IOUT(Q)}$	V_{FS}	V		4		STK-616Z-XXMFU5
Internal output resistance	R_{out}	Ω		2		STK-616Z-XXMFU5
Rated linearity error	E_{LIN}	% I_{PN}		±1.5		± I_{PN}
Step response time	t_{res}	μs		0.05		@90% of I_{pn} STK-616Z-XXMFU5
Frequency bandwidth (-3dB)	BW	MHz		2		@-3dB STK-616Z-XXMFU5
Output voltage noise	V_{noise}	mVpp		10		@1.4 MHz
Accuracy @ 25°C	E_{TOT}	% of I_{PN}		±1.5		All
Accuracy @ -40°C ~ 105°C	E_{TOT}	% of I_{PN}		±3.5		All

7. Electrical data STK-616Z-XXMFB3

 Condition: $T_A = 25^{\circ}\text{C}$, $V_{CC} = 3.3\text{ V}$

Parameter	Symbol	Unit	Min	Typ	Max	Comment
Supply voltage	V_{CC}	V		3.3±5%		STK-616Z-XXMFB3
Current consumption	I_{CC}	mA		6		STK-616Z-XXMFB3
Primary conductor resistance	R_{pr}	mΩ		0.9		STK-616Z-XXMFB3
Quiescent voltage Vout @ 0 A	$V_{IOUT(Q)}$	V		1.65±0.05		STK-616Z-XXMFB3
Zero Current Reference Voltage	V_{REF}	V		1.65±0.05		STK-616Z-XXMFB3
Peak output voltage (Vout @ $+I_{pm}$) - $V_{IOUT(Q)}$	V_{FS}	V		1.32		STK-616Z-XXMFB3
Internal output resistance	R_{out}	Ω		2		STK-616Z-XXMFB3
Rated linearity error	E_{LIN}	% I_{PN}		±1.5		± I_{PN}
Step response time	t_{res}	μs		0.05		@90% of I_{pn} STK-616Z-XXMFB3
Frequency bandwidth (-3dB)	BW	MHz		2		@-3dB STK-616Z-XXMFB3

Output voltage noise	Vnoise	mVpp		10		@1.4 MHz
Accuracy @ 25°C	E _{TOT}	% of I _{PN}		±1.5		All
Accuracy @ -40°C ~ 105°C	E _{TOT}	% of I _{PN}		±3.5		All

8. Electrical data STK-616Z-XXMFU3

Condition: T_A = 25°C, V_{CC} = 3.3 V

Parameter	Symbol	Unit	Min	Typ	Max	Comment
Supply voltage	V _{CC}	V		3.3±5%		STK-616Z-XXMFU3
Current consumption	I _{CC}	mA		6		STK-616Z-XXMFU3
Primary conductor resistance	R _{pr}	mΩ		0.9		STK-616Z-XXMFU3
Quiescent voltage Vout @ 0 A	V _{IOUT(Q)}	V		0.5±0.05		STK-616Z-XXMFU3
Zero Current Reference Voltage	V _{REF}	V		0.5±0.05		STK-616Z-XXMFU3
Peak output voltage (Vout @ +I _{pm}) - V _{IOUT(Q)}	V _{FS}	V		2.64		STK-616Z-XXMFU3
Internal output resistance	R _{out}	Ω		2		STK-616Z-XXMFU3
Rated linearity error	E _{LIN}	% I _{PN}		±1.5		±I _{PN}
Step response time	t _{res}	μs		0.05		@90% of I _{pn} STK-616Z-XXMFU3
Frequency bandwidth (-3dB)	BW	MHz		2		@-3dB STK-616Z-XXMFU3
Output voltage noise	Vnoise	mVpp		10		@1.4 MHz
Accuracy @ 25°C	E _{TOT}	% of I _{PN}		±1.5		All
Accuracy @ -40°C ~ 105°C	E _{TOT}	% of I _{PN}		±3.5		All

9. Typical Application Circuit

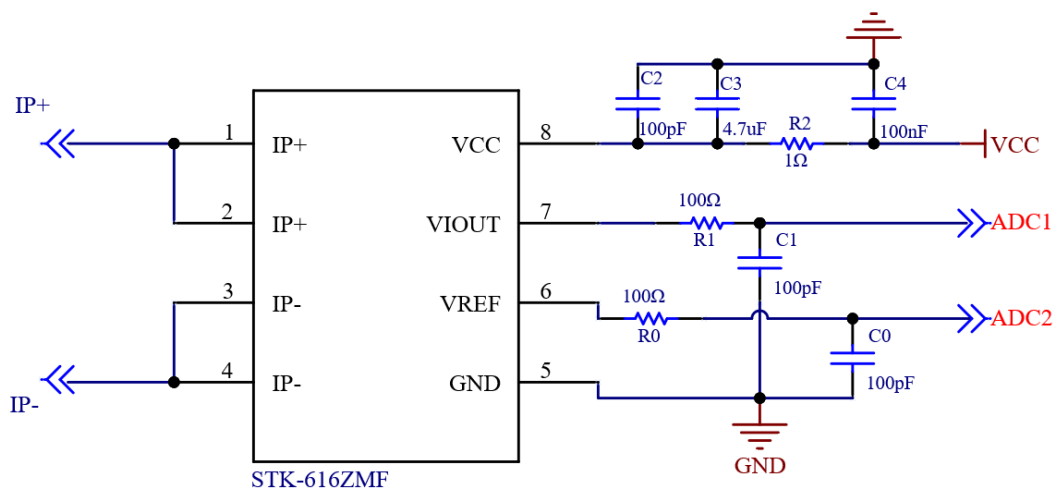

10. Characteristic Definitions

SENSITIVITY (Sens)

The change in sensor output in response to a 1 A change through the primary conductor. The sensitivity is the sensor gain (mv/A) for the full-scale current of the device. The sensitivity is fixed and does not change with the supply voltage.

ZERO CURRENT OUTPUT VOLTAGE (VIOUT(Q))

The output of the sensor when the primary current is zero. When the power supply is 5 V, it nominally remains at 2.5 V for a bidirectional device. When the power supply is 3.3 V, it nominally remains at 1.65 V for a bidirectional device.

11. Continues current vs working temperature

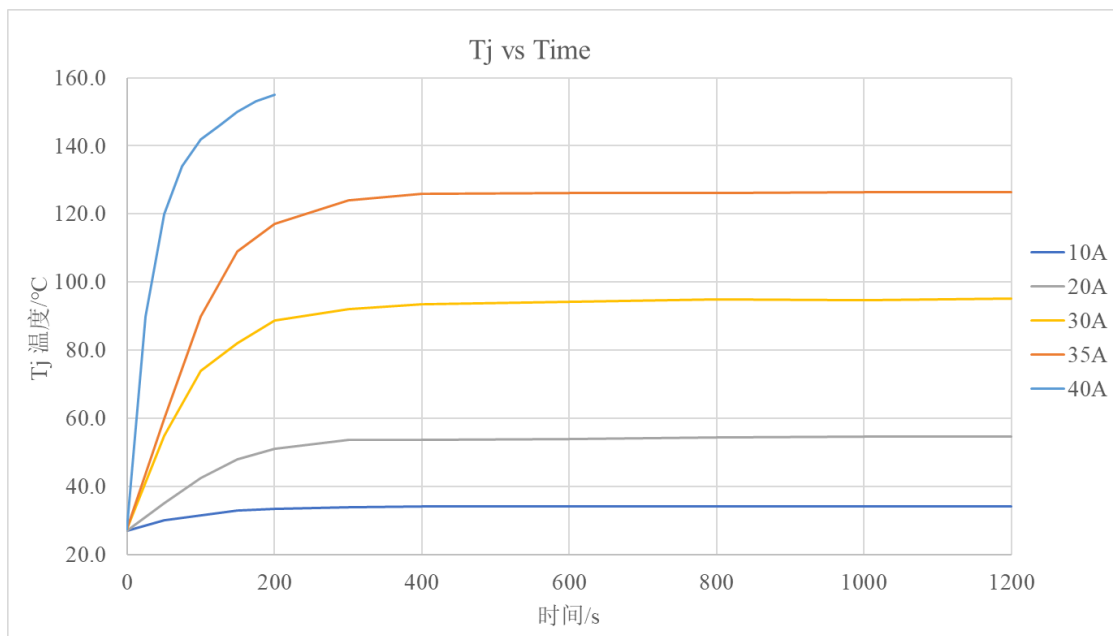

12. Dimension & Pin Definitions

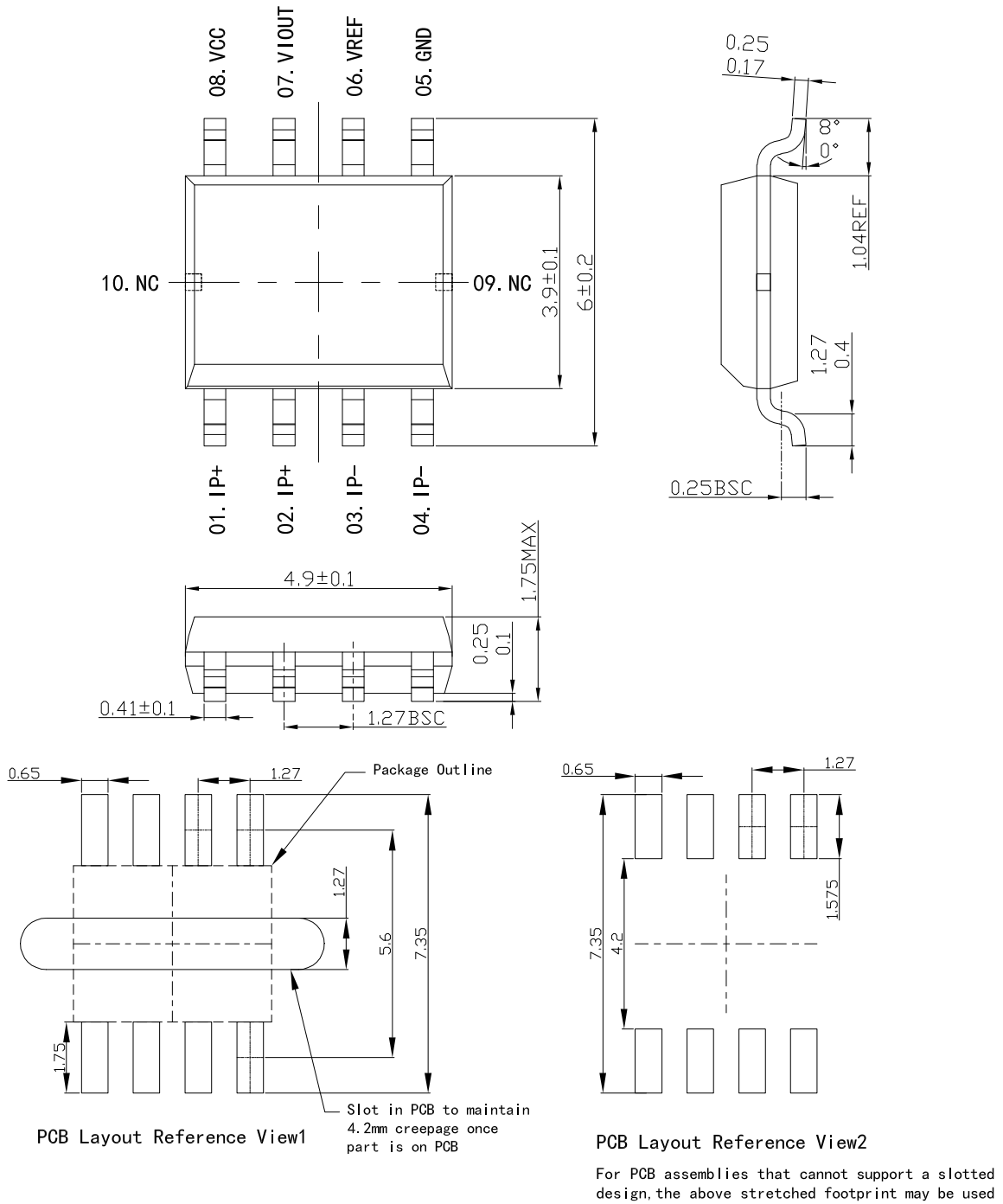

13. Pin definitions

Pin definition for product with OCD function

PIN	Symbol	Description
1,2	IP+	Primary conductor pin (+)
3,4	IP-	Primary conductor pin (-)
5	GND	Ground pin (GND)
6	VREF	Zero current voltage reference
7	VIOUT	Sensor output pin
8	VCC	Power supply pin

14. Frequency bandwidth of STK-616Z-XXMFBX

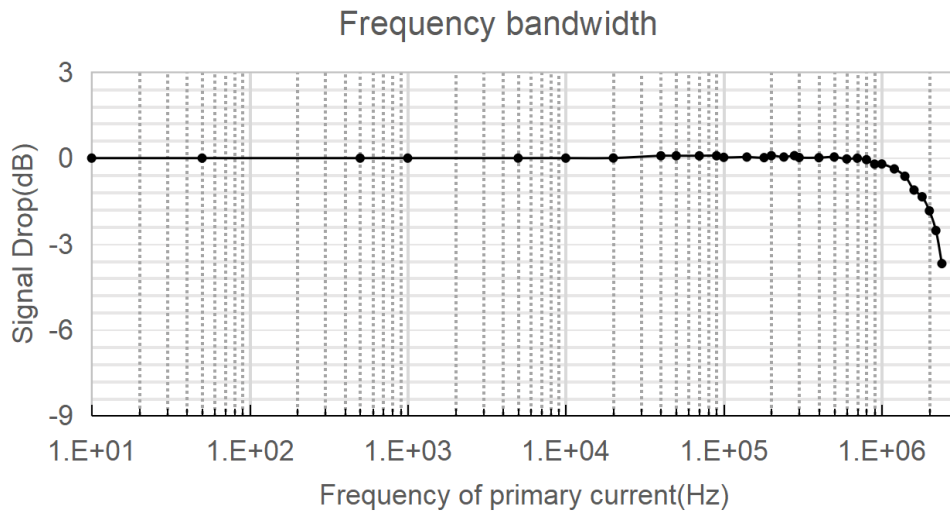

15. Step response time of STK-616Z-XXMFBX

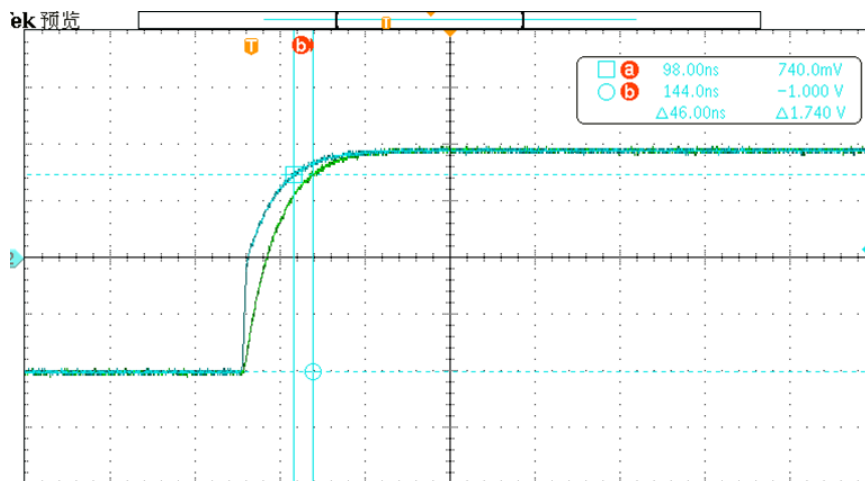

The typical frequency response of STK-616ZMF current sensor. The response time from 90% of the primary current to 90% of the secondary output is 0.05 μ s.

16. The delay time of the Triangular wave

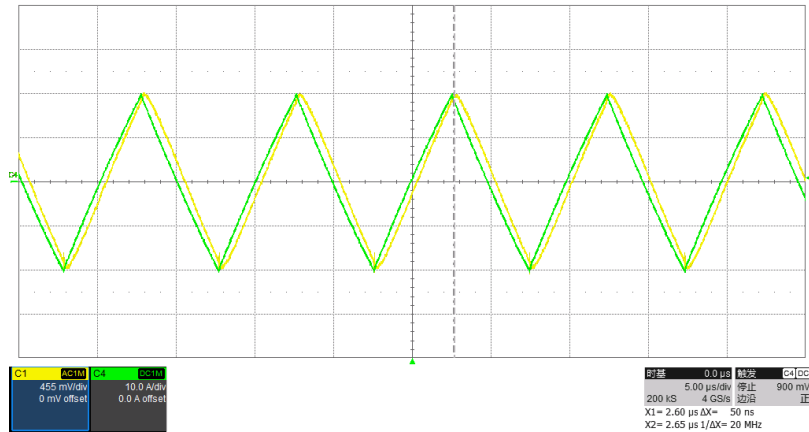

100 kHz Triangular delay---0.05μs

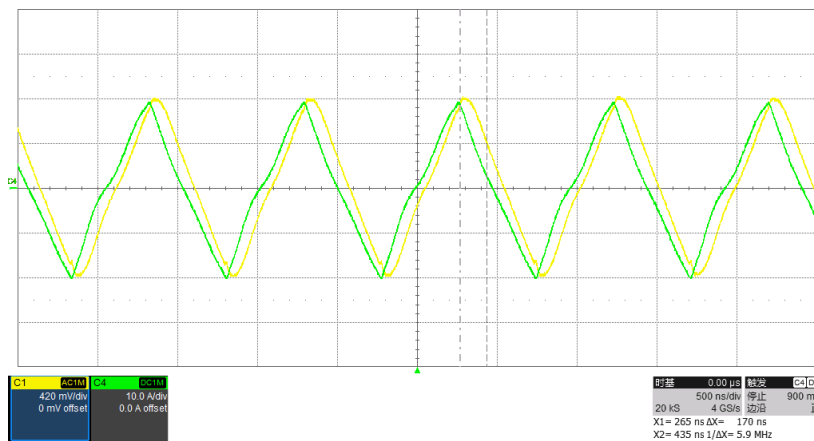

1 MHz Triangular delay---0.05μs

17. Package materials information

TAPE AND REEL INFORMATION

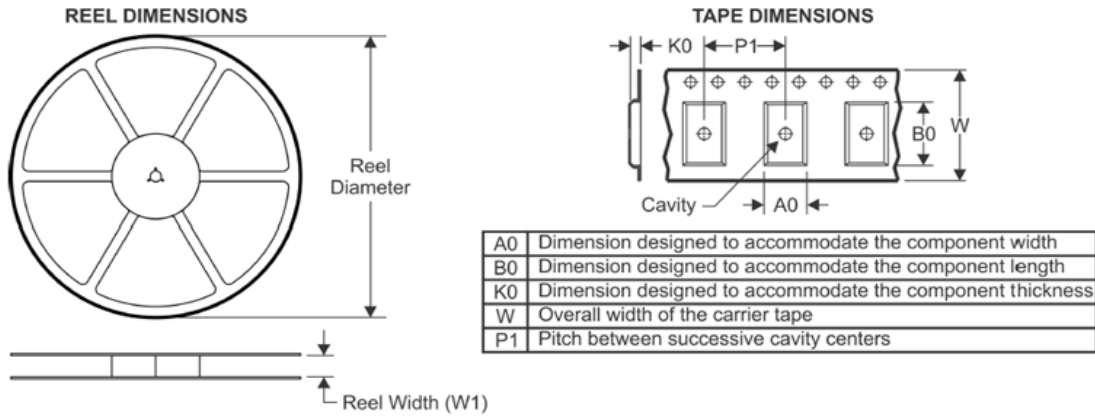

QUADRANT ASSIGNMENTS FOR PIN 1 ORIENTATION IN TAPE

